

3A Low Dropout Positive Regulator

FEATURES

- Dropout Voltage 1.3V at 3A Output Current.
- Fast Transient Response.
- Extremely Tight Line and Load Regulation.
- Current Limiting and Thermal Protection.
- Adjustable Output Voltage or Fixed 1.5V, 1.8V, 2.5V and 3.3V.
- Standard 3-Pin Power Packages.

APPLICATIONS

- Mother Board I/O Power Supplies.
- Microprocessor Power Supplies.
- High Current Regulator.
- Post Regulator for Switching Supply.

DESCRIPTION

The AIC1085 is a low dropout three terminal regulator with 3A output current capability. The output voltage is adjustable with the use of a resistor divider or fixed 1.5V, 1.8V, 2.5V and 3.3V. Dropout voltage is guaranteed to be at a maximum of 1.4V with the maximum output current. Its low dropout voltage and fast transient response make it ideal for low voltage microprocessor applications. Current limiting and thermal protection provides protection against any overload condition that would create excessive junction temperatures.

TYPICAL APPLICATION CIRCUIT

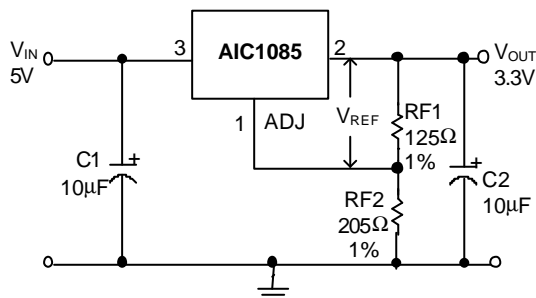

Adjustable Voltage Regulator

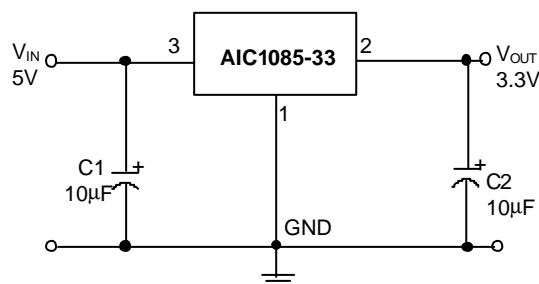

Fixed Voltage Regulator

$$V_{REF} = V_{OUT} - V_{ADJ} = 1.25V \text{ (typ.)}$$

$$V_{OUT} = V_{REF} \times \left(1 + \frac{RF2}{RF1}\right) + I_{ADJ} \times RF2$$

$$I_{ADJ} = 55 \mu A \text{ (typ.)}$$

- (1) C1 needed if device is far away from filter capacitors.
- (2) C2 required for stability.

ORDERING INFORMATION

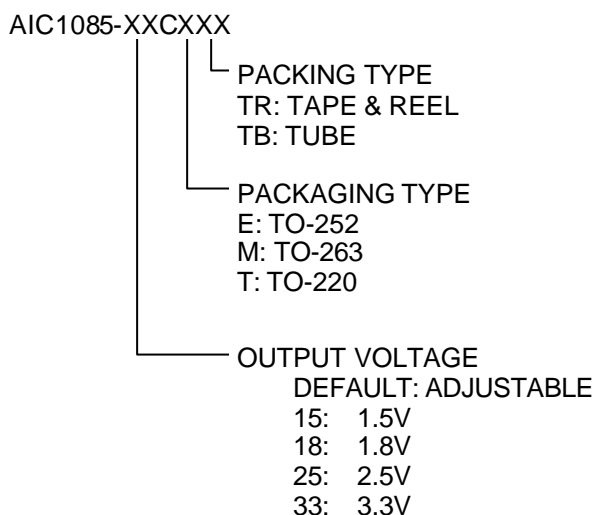

Example: AIC1085-15CETR
 → 1.5V version in TO-252 Package
 & Taping & Reel Packing Type

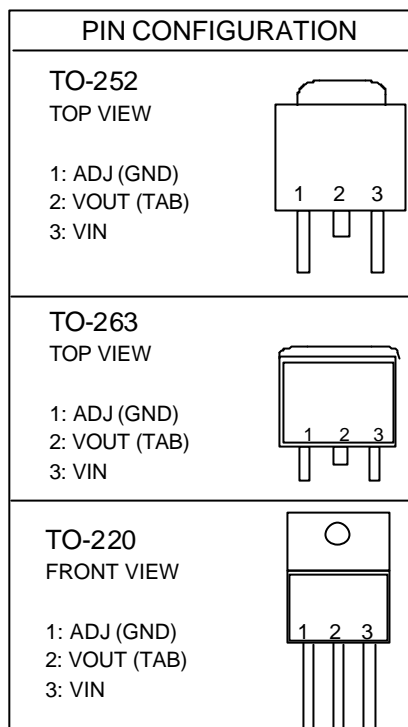

ABSOLUTE MAXIMUM RATINGS

VIN pin to ADJ/ GND pin.....	7V
Operating Junction Temperature Range.....	0°C~ 125°C
Storage Temperature Range.....	- 65°C ~ 150°C
Thermal Resistance Junction to Case TO-252.....	12.5°C/W
TO-263, TO-220.....	3°C /W
Thermal Resistance Junction to Ambient TO-252.....	100°C/W
(Assume no ambient airflow, no heatsink) TO-263.....	60°C /W
TO-220.....	50°C /W
Lead Temperature (Soldering) 10 sec.....	260°C

TEST CIRCUIT

Refer to TYPICAL APPLICATION CIRCUIT.

ELECTRICAL CHARACTERISTICS ($V_{IN}=5V$, $T_J=25^\circ C$, $I_O=10mA$, Unless otherwise specified)

PARAMETER	TEST CONDITIONS	MIN.	TYP.	MAX.	UNIT
Reference Voltage ($V_{OUT}-V_{ADJ}$)	AIC1085 (ADJ) $T_J=25^\circ C$	1.238	1.25	1.262	V
Output Voltage	AIC1085-15, $V_{IN}=5V$ AIC1085-18, $V_{IN}=5V$ AIC1085-25, $V_{IN}=5V$ AIC1085-33, $V_{IN}=5V$	1.48 1.78 2.47 3.26	1.50 1.80 2.50 3.30	1.52 1.82 2.53 3.34	V
Line Regulation	ADJ: $2.65V \leq V_{IN} \leq 7V$, $V_{OUT}=1.25V$ Fix : $V_{OUT}+1.4V \leq V_{IN} \leq 7V$, $T_J=25^\circ C$		0.015	0.2	%
Load Regulation	$10mA < I_O < 3A$ $T_J=25^\circ C$			0.6	%
Dropout Voltage	$\Delta V_{OUT}, \Delta V_{REF}=1\%$ $10mA \leq I_O \leq 3A$ $0^\circ C \leq T_J \leq 125^\circ C$		1.3	1.4	V
Current Limit	$0^\circ C \leq T_J \leq 125^\circ C$	3	4		A
Adjusted Pin Current (I_{ADJ})	$2.65V \leq V_{IN} \leq 7V$		55	120	μA
Adjusted Pin Current Change (ΔI_{ADJ})	$2.65V \leq V_{IN} \leq 7V$ $0^\circ C \leq T_J \leq 125^\circ C$		0.2	5	μA
Temperature Stability	$I_O=0.5A$ $0^\circ C \leq T_J \leq 125^\circ C$		0.5		%
Minimum Load Current	$0^\circ C \leq T_J \leq 125^\circ C$		5	10	mA
RMS Output Noise (% of V_{OUT})	$10Hz \leq f \leq 10KHz$		0.003		%
Ripple Rejection Ratio	120Hz input ripple $C_{OUT}=25\mu F$ $(V_{IN}-V_{OUT})=3V$	60	72		dB

BLOCK DIAGRAM

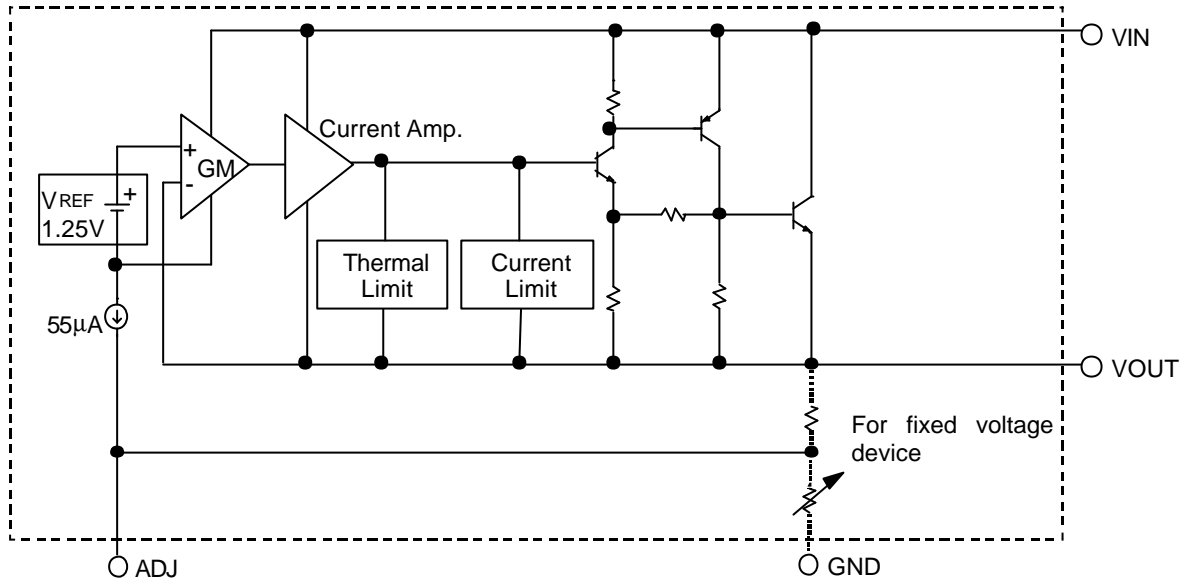

PIN DESCRIPTIONS

- ADJ PIN - Providing $V_{REF}=1.25V$ (typ.) for adjustable V_{OUT} . $V_{REF}=V_{OUT}-V_{ADJ}$ and $I_{ADJ}=55\mu A$ (typ.)
- GND PIN - Power Ground.
- VOUT PIN - Adjustable output voltage.
- VIN PIN - Power Input.

TYPICAL PERFORMANCE CHARACTERISTICS

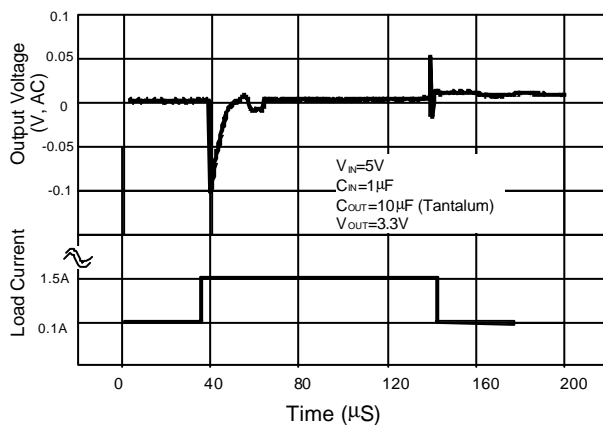

Fig. 1 Load Transient Response

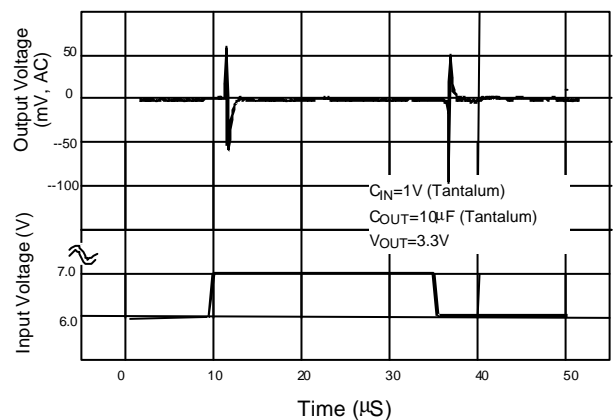

Fig. 2 Line Transient Response

TYPICAL PERFORMANCE CHARACTERISTICS (Continued)

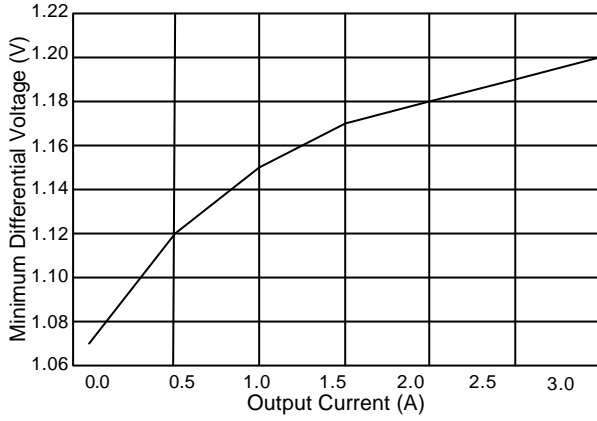

Fig. 3 Dropout Voltage (V_{OUT}=3.3V)

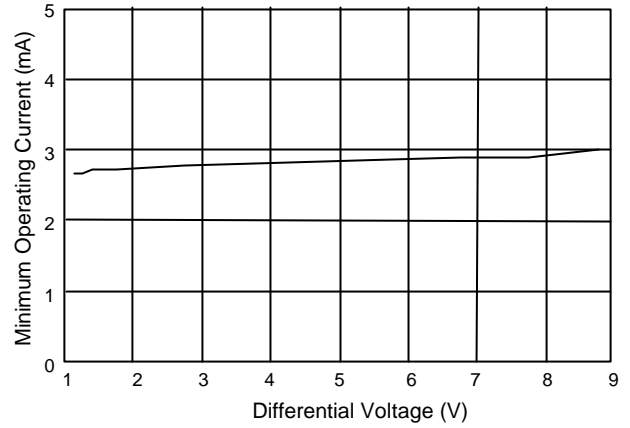
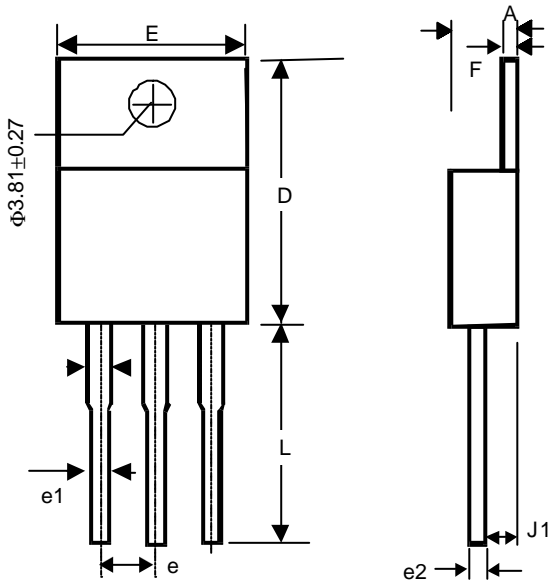

Fig. 4 Minimum Operating Current

PHYSICAL DIMENSIONS

- TO-220 (unit: mm)



SYMBOL	MIN	MAX
A	3.56	4.82
D	14.23	16.51
E	9.66	10.66
e	2.29	2.79
e1	0.50	1.15
e2	-	1.10
F	0.51	1.39
J1	2.04	2.92
L	12.70	14.73

● TO-263 (unit: mm)

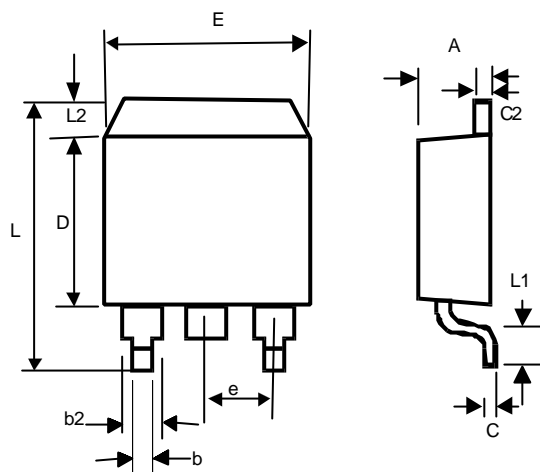

SYMBOL	MIN	MAX
A	4.06	4.83
b	0.50	1.00
b2	1.14	1.40
C	-	0.7
c2	1.14	1.40
D	8.63	9.66
E	9.65	10.29
e	2.54 (TYP.)	
L	14.60	15.88
L1	2.28	2.80
L2	-	1.40

● TO-252 (unit: mm)

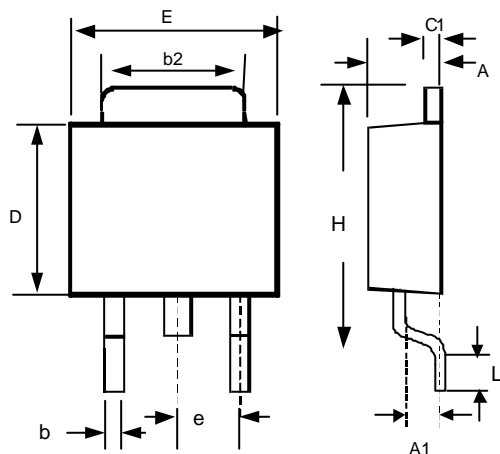

SYMBOL	MIN	MAX
A	2.19	2.38
A1	1.02	1.27
b	0.64	0.88
b2	5.21	5.46
C1	0.46	0.58
D	5.33	5.59
E	6.35	6.73
e	2.28 (TYP.)	
H	9.40	10.42
L	0.51	-