

USB High-Side Power Switch

FEATURES

- 120mΩ (5V Input) High-Side MOSFET Switch.
- 500mA Continuous Load Current.
- 80μA Typical On-State Supply Current.
- Current-Limit / Short Circuit Protection.
- Thermal Limiting Protection under Overcurrent Condition.
- Undervoltage Lockout Ensures that Switch is off at Start Up.
- Output can be Forced Higher than Input (Off-State).
- Slow Turn ON and Fast Turn OFF.

APPLICATIONS

- Motherboard USB Management.
- USB Power Management.
- Hot Plug-In Power Supplies.
- Battery-Charger Circuit.
- Power Distribution Switch.

DESCRIPTION

The AIC1520 is an integrated high-side power switch for self-powered and bus-powered Universal Serial Bus (USB) applications. The high-side switch is a MOSFET with 120mΩ $R_{DS(ON)}$, which meets USB voltage drop requirements for maximum transmission wire length.

Output current is typically limited to 1.0A, well below the 5A safety requirement, and thermal shutdown function shuts the switch off to prevent damage under overcurrent conditions.

Guaranteed minimum output rise time limits inrush current during hot plug-in, minimizing EMI and preventing the voltage at upstream port from dropping excessively.

TYPICAL APPLICATION CIRCUIT

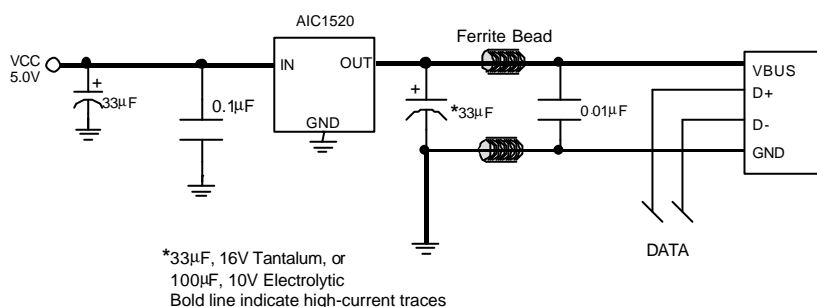

USB High-Side Power Switch

ORDERING INFORMATION

AIC1520CXXX

PACKING TYPE
 TR: TAPE & REEL
 BG: BAG

 PACKAGING TYPE
 X: SOT-89
 Z: TO-92

Example: AIC1520CXTR

→ in SOT-89 Package & Taping &
 Reel Packing Type

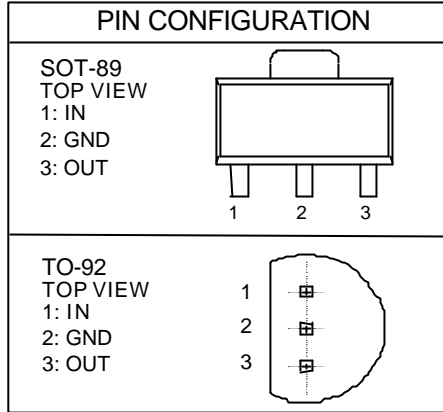
ABSOLUTE MAXIMUM RATINGS

Supply Voltage (V_{IN}) 7.0V
 Operating Temperature Range -40°C ~ 85°C
 Storage Temperature Range -65°C ~ 150°C

ELECTRICAL CHARACTERISTICS ($V_{IN}=5V$, $T_A=25^\circ C$, unless otherwise specified.)

PARAMETERS	CONDITIONS	MIN.	TYP.	MAX.	UNIT
Supply Current	Switch On, OUT=Open		80	100	μA
Output MOSFET Resistance	$I_{OUT} = 500mA$		120	180	$m\Omega$
Output Turn-On Rise Time	$R_L = 10\Omega$		500		μS
Output Turn-Off Fall Time	$R_L = 10\Omega$		0.2	10	μS
Output Leakage Current				2	μA
Current Limit Threshold		0.6	1.0	1.25	A
Thermal Limit			110		$^\circ C$
UVLO Threshold	V_{IN} Increasing		2.8		V
	V_{IN} Decreasing		2.6		

TYPICAL PERFORMANCE CHARACTERISTICS

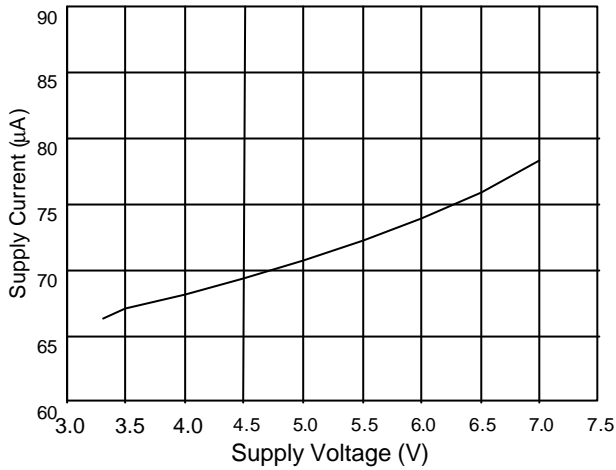

Fig. 1 On-State Supply Current vs. Supply

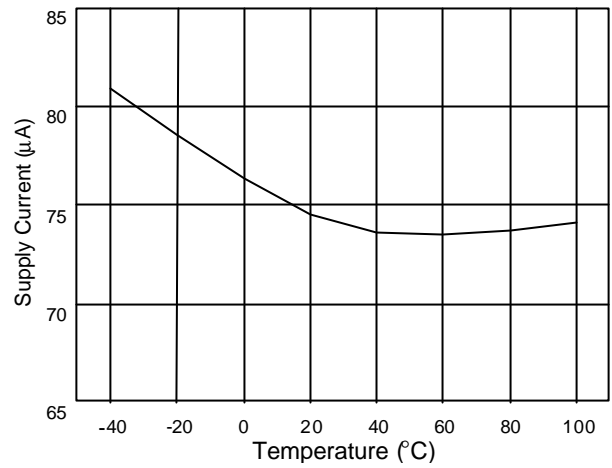

Fig. 2 On-State Supply Current vs. Temperature

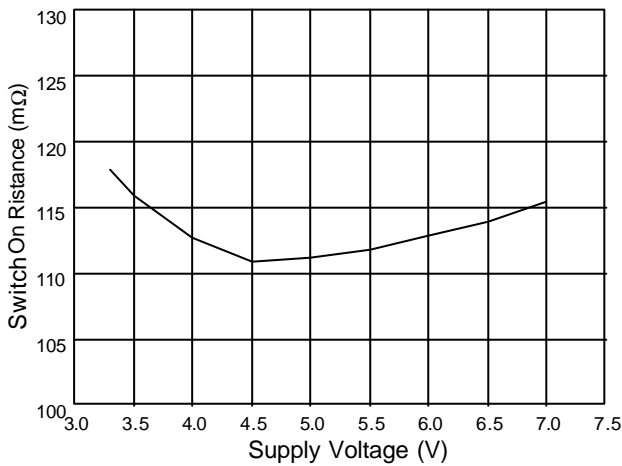

Fig. 3 Output On Resistance vs. Supply Voltage

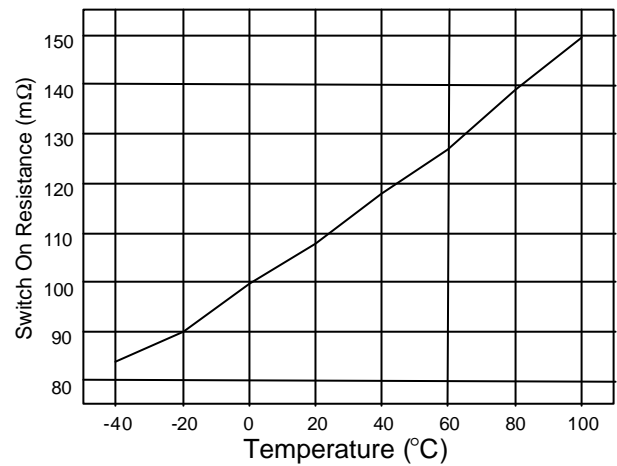

Fig. 4 Output On Resistance vs. Temperature

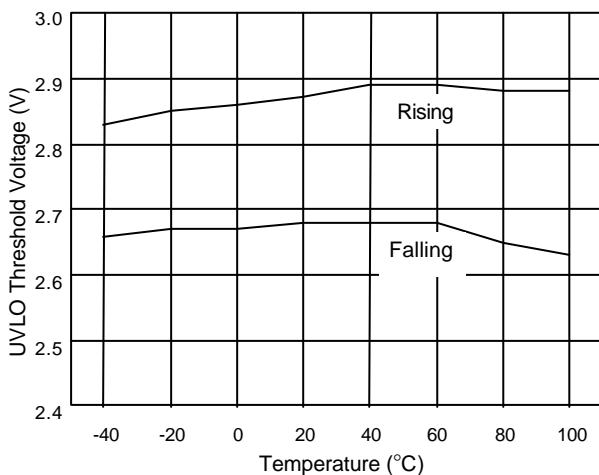

Fig. 5 UVLO Threshold Voltage vs. Temperature

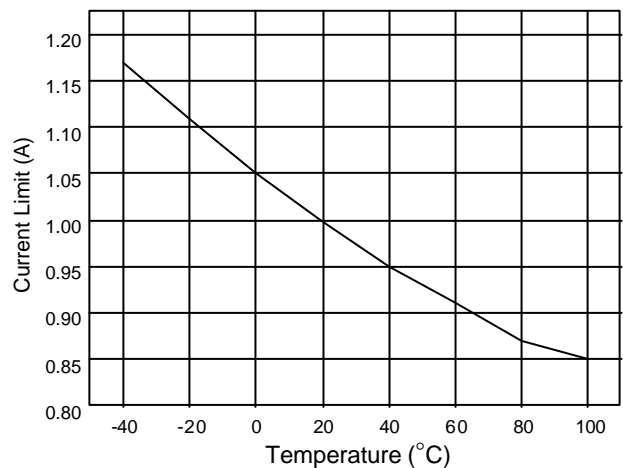

Fig. 6 Current Limit Threshold vs. Temperature

TYPICAL PERFORMANCE CHARACTERISTICS (Continued)

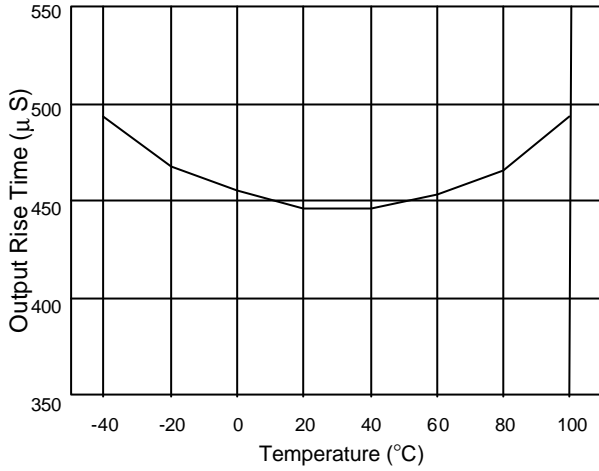

Fig. 7 Output Rise Time vs. temperature

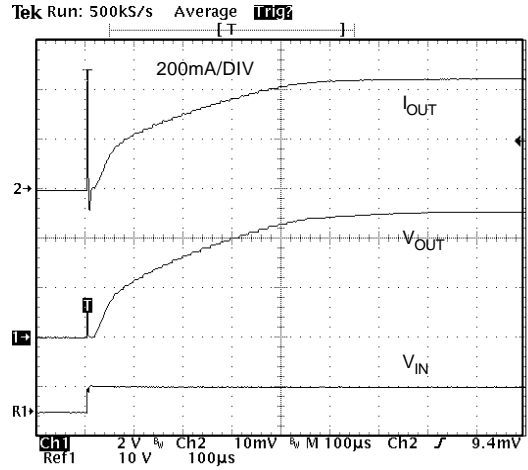

Fig. 8 Turn On Rising Time (10Ω loading)

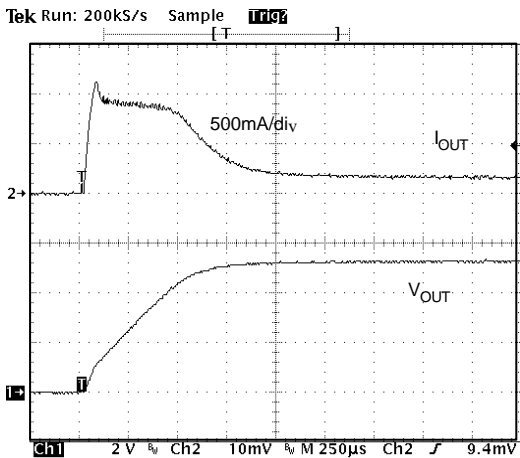

Fig. 9 Turn On Characteristic (35Ω, 100μF Loading)

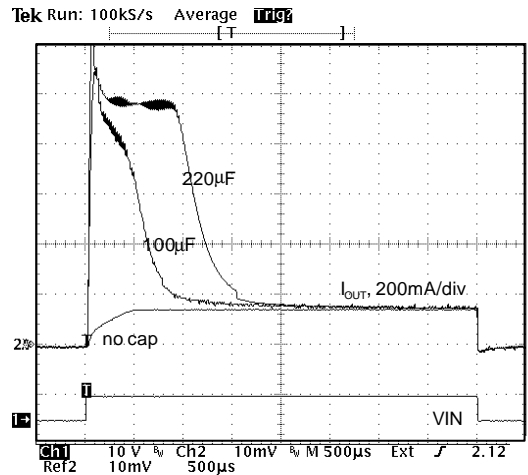

Fig. 10 Turn On Characteristic (35Ω Loading)

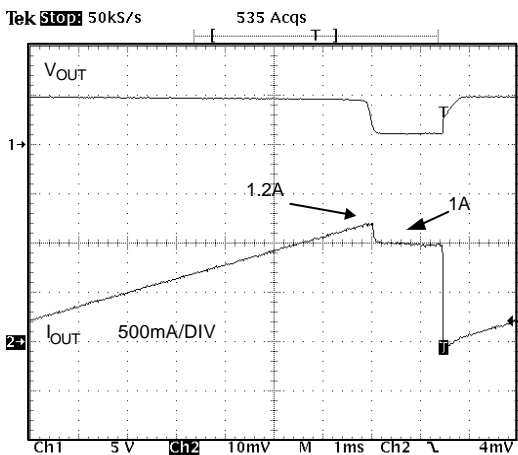

Fig. 11 Current Limit Threshold

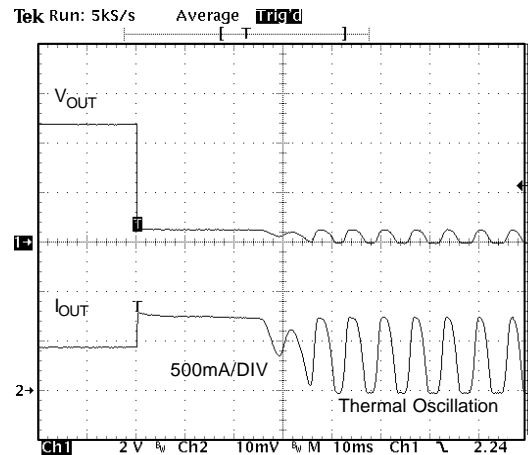

Fig. 12 Short Circuit Testing

TYPICAL PERFORMANCE CHARACTERISTICS (Continued)

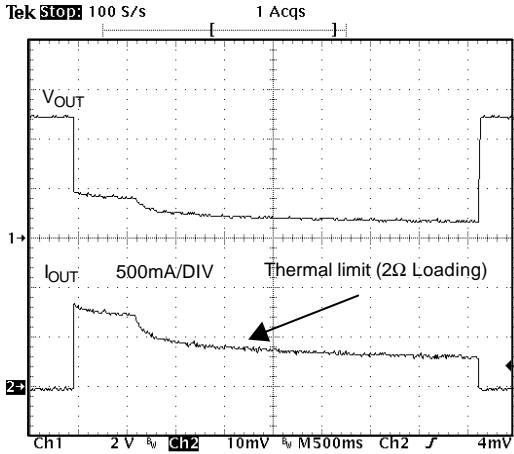

Fig. 13 Thermal Limiting Transient Response

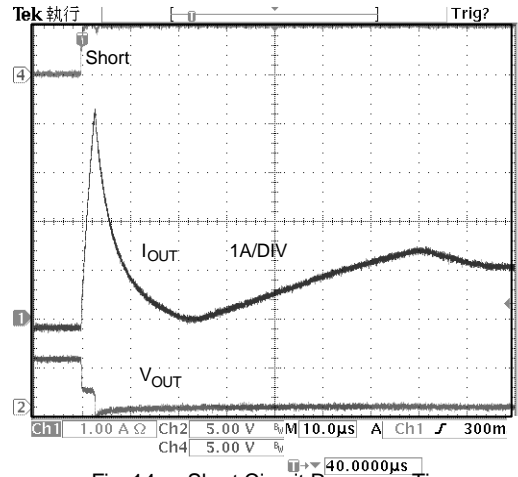
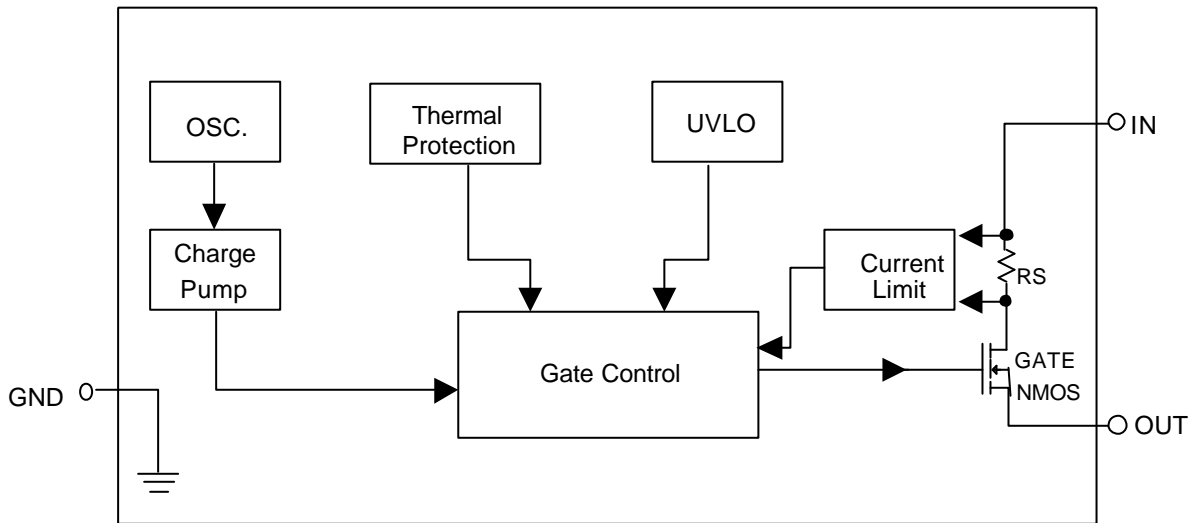

Fig. 14 Short Circuit Response Time

BLOCK DIAGRAM



PIN DESCRIPTIONS

- PIN 1: IN - Power supply input.
- PIN 2: GND - Chip power ground.
- PIN 3: OUT - MOSFET switch output.

■ APPLICATION INFORMATIONS

Current Limit

The current limit threshold is preset internally. It protects the output MOSFET switches from damage due to undesirable short circuit conditions or excess inrush current often encountered during hot plug-in. AIC1520 allows a minimum current of 0.5A through the MOSFET switches.

Thermal Protection

When the chip temperature exceeds 110°C, the thermal protection function works.

Supply Filtering

A 0.1 μ F to 1 μ F bypass capacitor from IN to GND, located near the device, is strongly recommended to control supply transients. Without a bypass capacitor, an output short may cause sufficient ringing on the input (from supply lead inductance) to damage internal control circuitry.

Transient Drop Requirements

The USB supports dynamic attachment (hot plug-in) of peripherals. A current surge is caused by the input capacitance of downstream device. Ferrite beads are recommended in series with all power and ground connector pins. Ferrite beads reduce EMI and limit the inrush current during hot-attachment by filtering high-frequency signals.

Short Circuit Transient

Bulk capacitance provides the short-term transient current needed during a hot-attachment event. With a 33 μ F, 16V tantalum or 100 μ F, 10V electrolytic capacitor mounted close to downstream connector should provide transient drop protection.

Printed Circuit Layout

The power circuitry of USB printed circuit boards requires a customized layout to maximize thermal dissipation and to minimize voltage drop and EMI.

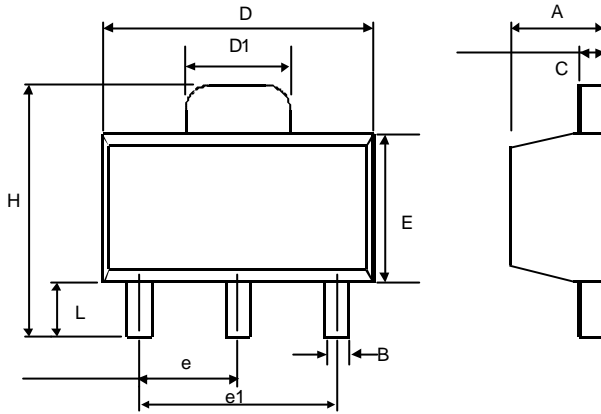
PHYSICAL DIMENSIONS
SOT-89 (unit: mm)

SYMBOL	MIN	MAX
A	1.40	1.60
B	0.36	0.48
C	0.35	0.44
D	4.40	4.60
D1	1.62	1.83
E	2.29	2.60
e	1.50 (TYP.)	
e1	3.00 (TYP.)	
H	3.94	4.25
L	0.89	1.20

SOT-89 MARKING

Part No.	Marking
AIC1520-CX	BG01

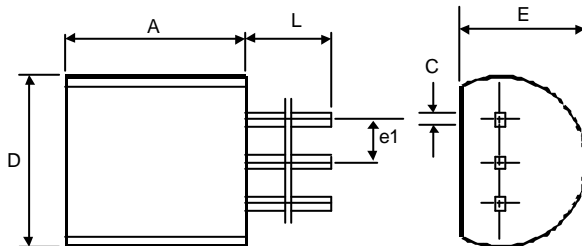
TO-92 (unit: mm)

SYMBOL	MIN	MAX
A	4.32	5.33
C	0.38 (TYP.)	
D	4.40	5.20
E	3.17	4.20
e1	1.27 (TYP.)	
L	12.7	-