

Quad USB High-Side Power Switch

FEATURES

- 110mΩ (5V Input) High-Side MOSFET Switch.
- 500mA Continuous Load Current per Channel.
- 220μA Typical On-State Supply Current.
- 1μA Typical Off-State Supply Current.
- Current-Limit / Short Circuit Protection.
- Thermal Shutdown Protection under Overcurrent Condition.
- Undervoltage Lockout Ensures that Switch is off at Start Up.
- Output can be Forced Higher than Input (Off-State).
- Open-Drain Fault Flag.
- Slow Turn ON and Fast Turn OFF.
- Enable Active-High or Active-Low.

APPLICATIONS

- USB Power Management.
- Hot Plug-In Power Supplies.
- Battery-Charger Circuit.

DESCRIPTION

The AIC1527 is a quad high-side power switch for self-powered and bus-powered Universal Serial Bus (USB) applications. One high-side switch is a MOSFET with 110mΩ $R_{DS(ON)}$, which meets USB voltage drop requirements for maximum transmission wire length.

Multi-purpose open-drain fault flag output indicates over-current limiting, thermal shutdown, or undervoltage lockout for each channel. Output current is typically limited to 1A, well below the 5A safety requirement, and the thermal shutdown function independently controls each channel under overcurrent condition.

Guaranteed minimum output rise time limits inrush current during hot plug-in, minimizing EMI and preventing the voltage at upstream port from dropping excessively.

TYPICAL APPLICATION CIRCUIT

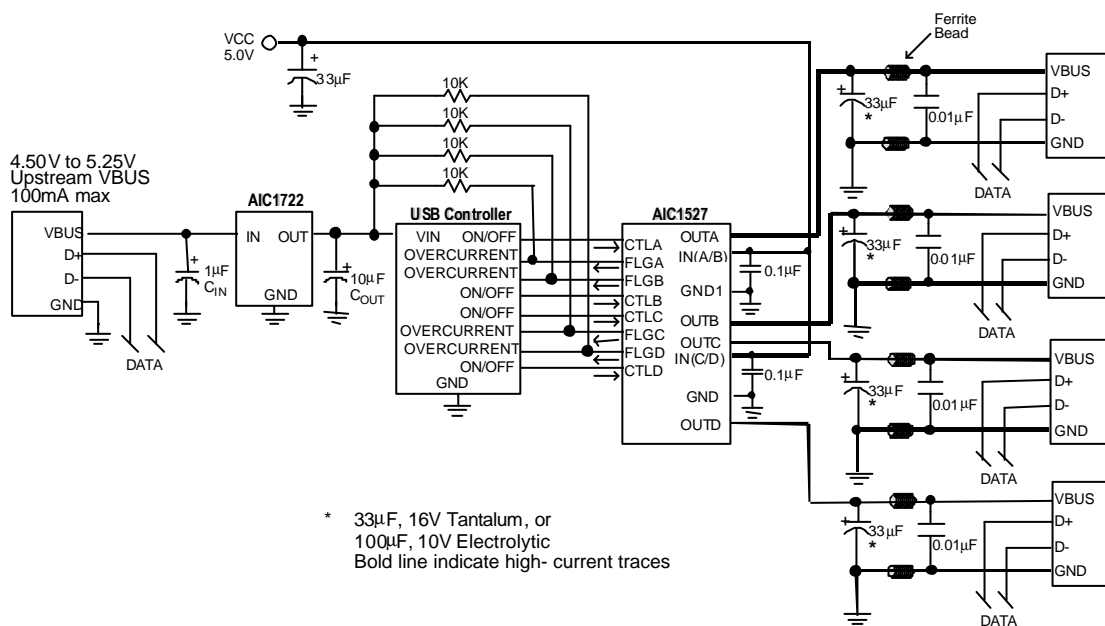

4-Port Self-Powered Hub

ORDERING INFORMATION

AIC1527-XCXXX

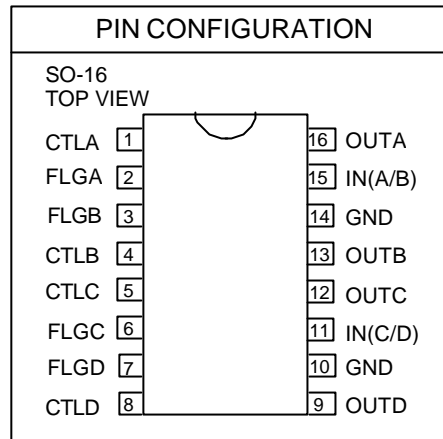
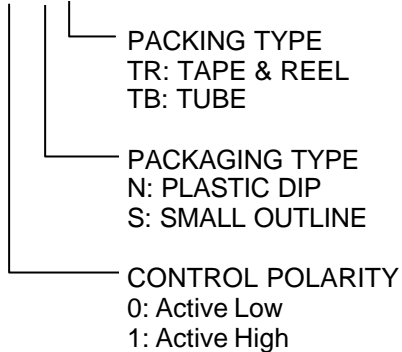

Example: AIC1527-0COTR

- Active Low Version, in SO-16 Package & Taping & Reel Packing Type (CN is not available in TR type.)

ABSOLUTE MAXIMUM RATINGS

Supply Voltage (V_{IN}).....	7.0V
Fault Flag Voltage (V_{FLG})	7.0V
Fault Flag Current (I_{FLG}).....	50mA
Control Input (V_{CTL})	-0.3V ~15V
Operating Temperature Range	-20°C~80°C
Storage Temperature Range	-65°C ~ 150°C

TEST CIRCUIT

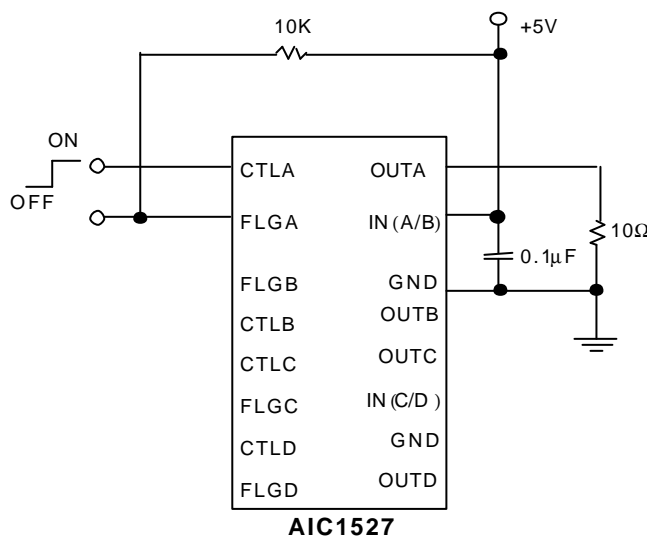

(For output reference only)

ELECTRICAL CHARACTERISTICS ($V_{IN}=5V$, $T_A=25^{\circ}C$, unless otherwise specified.)

PARAMETERS	CONDITIONS	MIN.	TYP.	MAX.	UNIT
Supply Current	$V_{CTL} = \text{Logic "0"} , \text{OUT} = \text{Open}$		1.50	10	μA
	$V_{CTL} = \text{Logic "1"} , \text{OUT} = \text{Open}$		220	320	
Control Input Voltage	$V_{CTL} = \text{Logic "0"}$			0.8	V
	$V_{CTL} = \text{Logic "1"}$	2.4			
Control Input Current	$V_{CTL} = \text{Logic "0"}$		0.01	1	μA
	$V_{CTL} = \text{Logic "1"}$		0.01	1	
Control Input Capacitance			1		pF
Output MOSFET Resistance			110	150	m Ω
Output Turn-On Rise Delay	$R_L = 10\Omega$ each Output		100		μS
Output Turn-On Rise Time	$R_L = 10\Omega$ each Output		1000	2500	μS
Output Turn-Off Delay	$R_L = 10\Omega$ each Output		0.8	20	μS
Output Turn-Off Fall Time	$R_L = 10\Omega$ each Output		0.7	20	μS
Output Leakage Current				10	μA
Current Limit Threshold		0.6	1.0	1.25	A
Overtemperature Shutdown Threshold	T_J Increasing		135		$^{\circ}C$
	T_J Decreasing		125		
Error Flag Output Resistance	$V_{IN} = 5V , I_L = 10\text{ mA}$		10	25	Ω
	$V_{IN} = 3.3V , I_L = 10\text{mA}$		15	40	
Error Flag Off Current	$V_{FLG} = 5V$		0.01	1	μA
UVLO Threshold	V_{IN} Increasing		2.6		V
	V_{IN} Decreasing		2.4		

TYPICAL PERFORMANCE CHARACTERISTICS

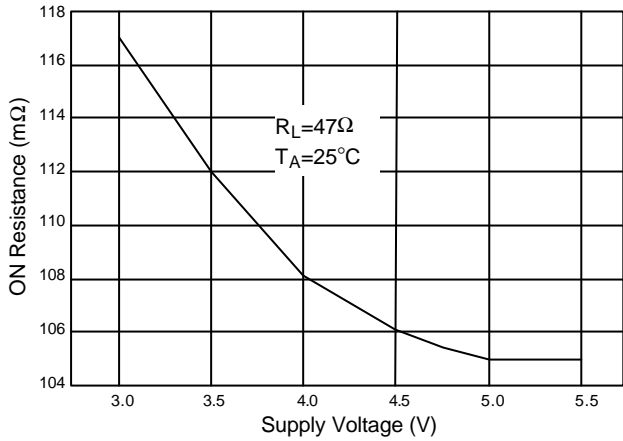

Fig. 1 ON Resistance vs. Supply Voltage

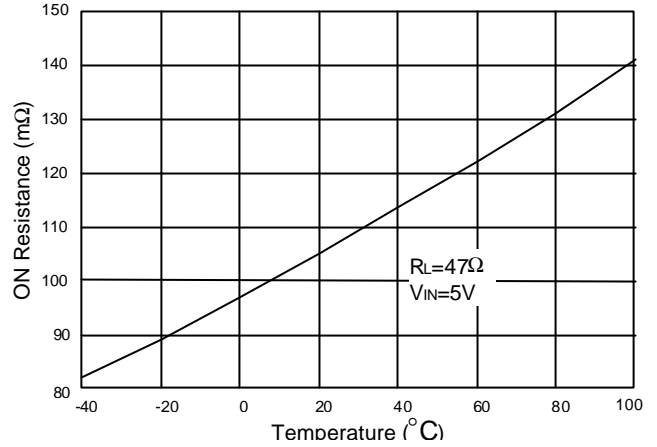

Fig. 2 Output On Resistance vs. Temperature

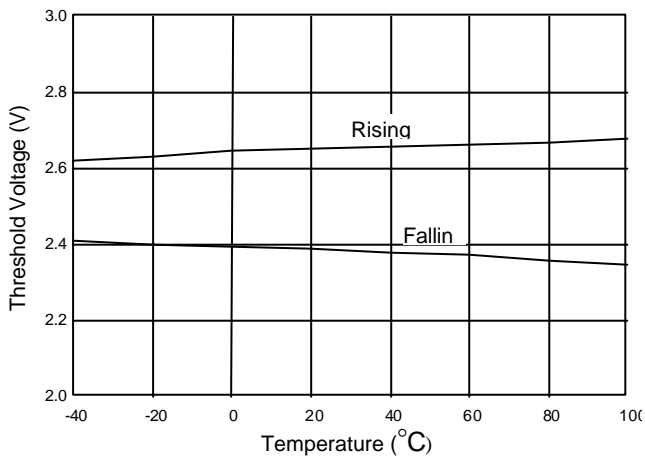

Fig. 3 UVLO Threshold Voltage vs. Temperature

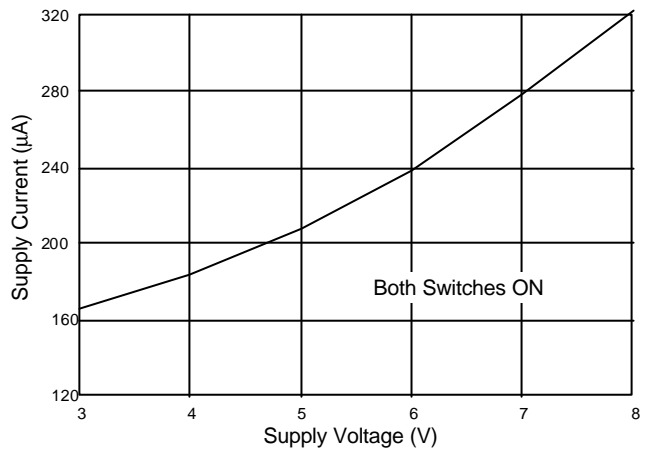

Fig. 4 ON-State Supply Current vs. Supply Voltage

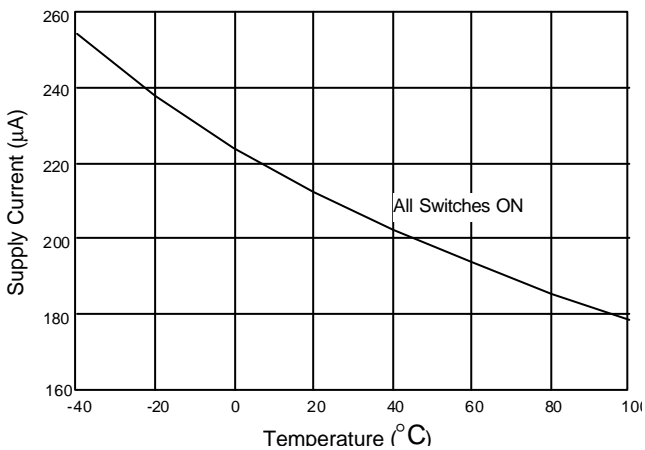

Fig. 5 ON-State Supply Current vs. Temperature

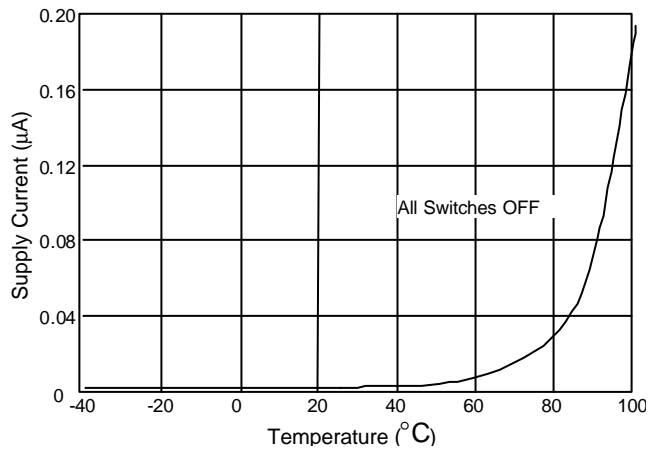

Fig. 6 OFF-State Current vs. Temperature

TYPICAL PERFORMANCE CHARACTERISTICS (Continued)

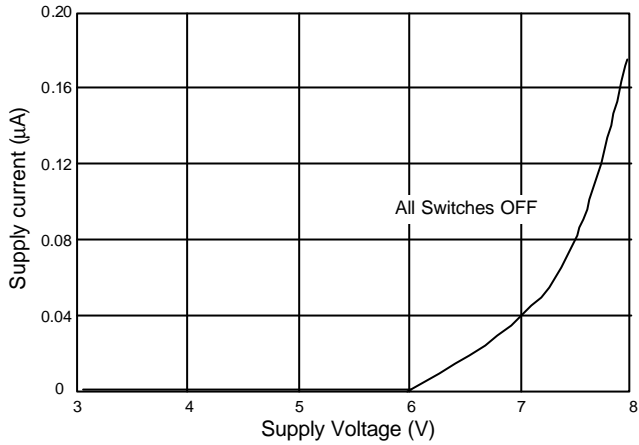

Fig. 7 OFF-State Current vs. Supply Voltage

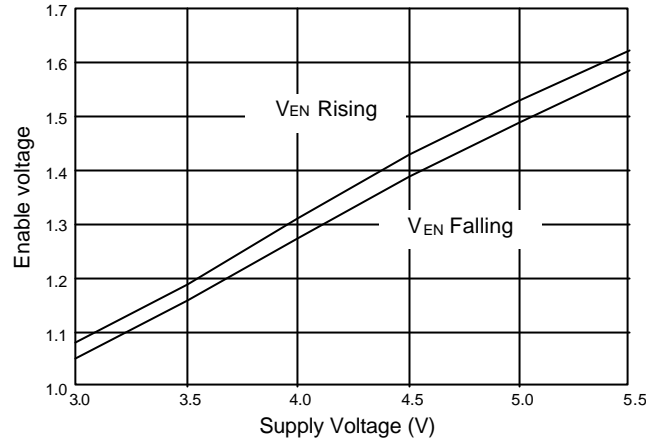

Fig. 8 Control Threshold vs. Supply Voltage

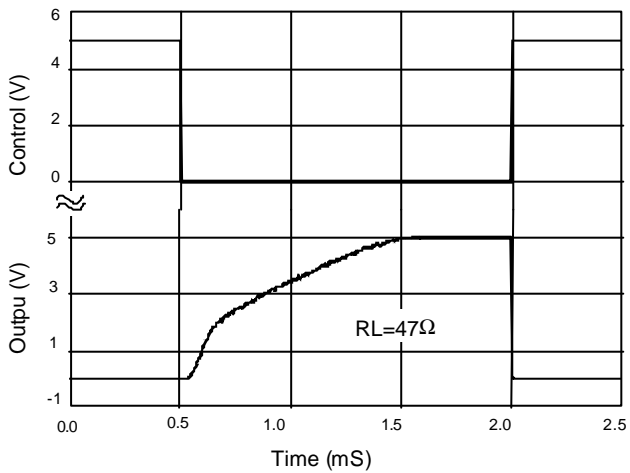
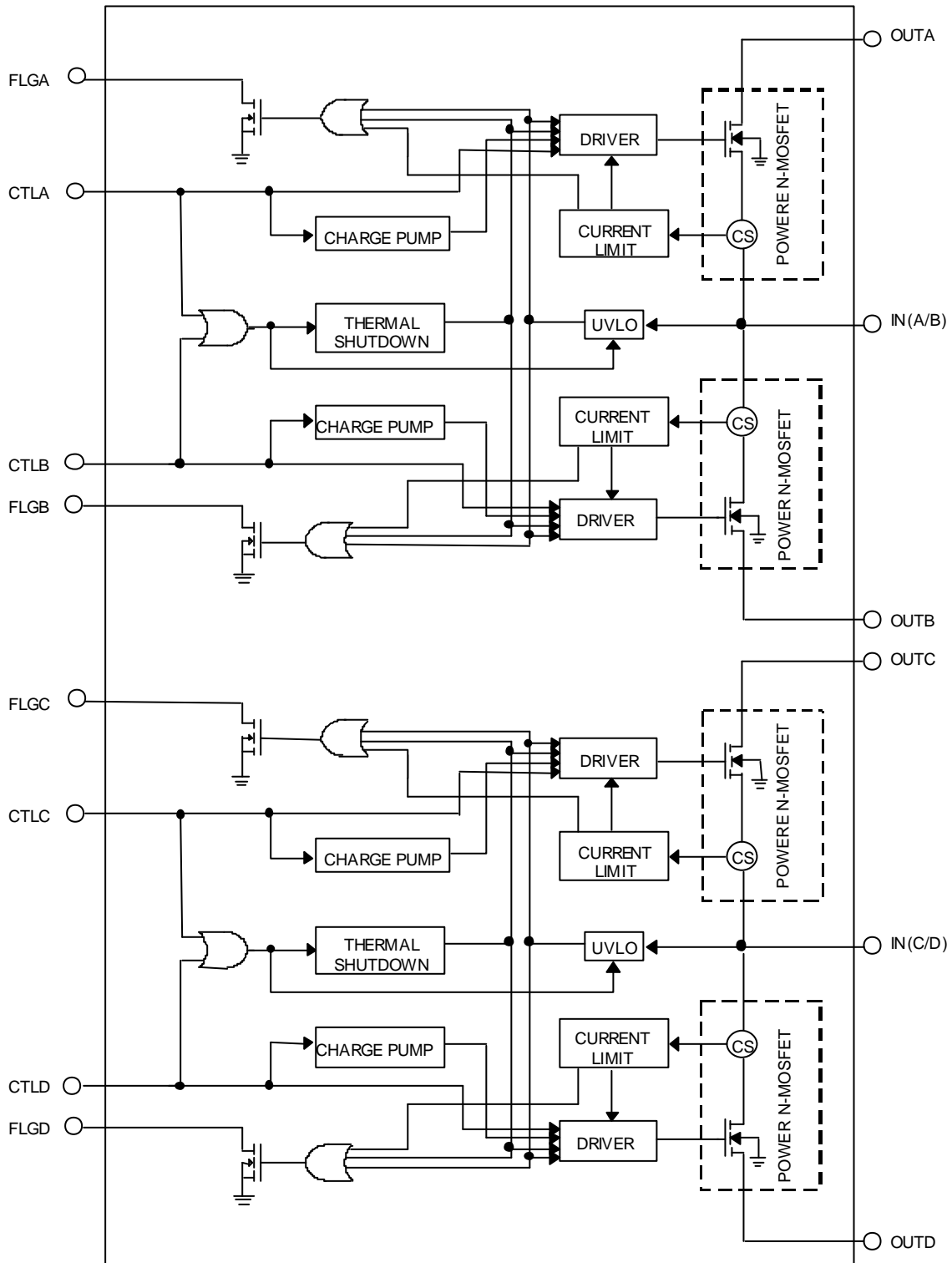

Fig. 9 Turn-On, Turn-Off Characteristics

■ BLOCK DIAGRAM



■ PIN DESCRIPTIONS

PIN 1(5):CTLA(C)- TTL compatible control input. It controls the turn-on/turn-off of channel A(C) MOSFET. Active High for AIC1527-1 and active low for AIC1527-0.

PIN 2(6):FLGA(C)- An active-low and open-drain fault flag output for channel A. It can indicate current limit if CTLA(C) is active. In normal mode operation (CTLA(C) or/and CLTB(D) is active), it also can indicate thermal shutdown or undervoltage.

PIN 3(7):FLGB(D)- An active-low and open-drain fault flag output for channel B(D). It can indicate current limit if CTLB(D) is active. In normal mode operation (CTLB(D) or/and CLTA(C) is active), it also can indicate

thermal shutdown or undervoltage.

PIN 4(8):CTLB(D)- TTL compatible control input. It controls the turn-on/turn-off of channel B(D) MOSFET. Active High for AIC1527-1 and active low for AIC1527-0.

PIN 9(13):OUTD(B)-Channel D(B) MOSFET switch output.

PIN 10,14:GND - Chip power return, Connect both pins to ground.

PIN 11:IN(C/D) - Channel C AND D power supply input.

PIN12(16):OUTC(A) -Channel C(A) MOSFET switch output.

PIN15: IN(A/B) - Channel A and B power supply input.

■ APPLICATION INFORMATIONS

● Error Flag

An open-drained output of an N-channel MOSFET, the FLG output is pulled low to signal the following fault conditions: input undervoltage, output current limit, and thermal shutdown.

● Current Limit

The current limit threshold is preset internally. It protects the output MOSFET switches from damage due to undesirable short circuit conditions or excess inrush current often encountered during hot plug-in. The low limit of the current limit threshold of the AIC1527 allows a minimum current of 0.5A through the MOSFET switches. A current limit condition will signal the error flag.

● Thermal Shutdown

When the chip temperature exceeds 135°C for any reason other than overcurrent fault of either one of the four MOSFET switches, the thermal shutdown function turns off all MOSFET switches and signal the error flag. A hysteresis of 10°C prevents the MOSFETs from turning back on until the chip temperature drops to below 125°C. However, if thermal shutdown is triggered by chip temperature rise due to overcurrent fault condition of either one of the MOSFET switches, the thermal shutdown function will only turn off the switch that is in overcurrent condition and the other switch can still remain its normal operation. In other words, the thermal shutdown function of the four switches is independent of each other in the case of overcurrent fault.

- **Supply Filtering**

A 0.1uF to 1uF bypass capacitor from IN to GND, located near the device, is strongly recommended to control supply transients. Without a bypass capacitor, an output short may cause sufficient ringing on the input (from supply lead inductance) to damage internal control circuitry.

- **Transient Droop Requirements**

USB support dynamic attachment (hot plug-in) of peripherals. A current surge is caused by the input capacitance of downstream device. Ferrite beads are recommended in series with all power and ground connector pins. Ferrite beads reduce EMI and limit the

inrush current during hot-attachment by filtering high-frequency signals.

- **Short Circuit Transient**

Bulk capacitance provides the short-term transient current needed during a hot-attachment event. With a 33uF, 16V tantalum or 100uF, 10V electrolytic capacitor mounted close to downstream connector per port should provide transient drop protection.

- **Printed Circuit Layout**

The power circuitry of USB printed circuit boards requires a customized layout to maximize thermal dissipation and to minimize voltage drop and EMI.

■ PHYSICAL DIMENSIONS

- **16 LEAD PLASTIC SO (150 mil) (unit: mm)**

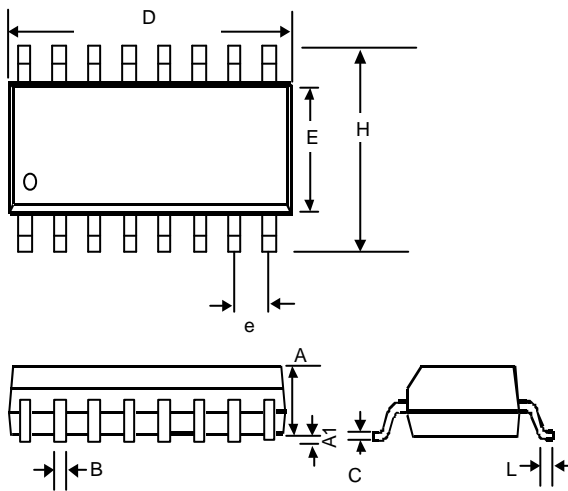

SYMBOL	MIN	MAX
A	1.35	1.75
A1	0.10	0.25
B	0.33	0.51
C	0.19	0.25
D	9.80	10.00
E	3.80	4.00
e	1.27 (TYP)	
H	5.80	6.20
L	0.40	1.27

● 16 LEAD PLASTIC DIP (unit: mm)

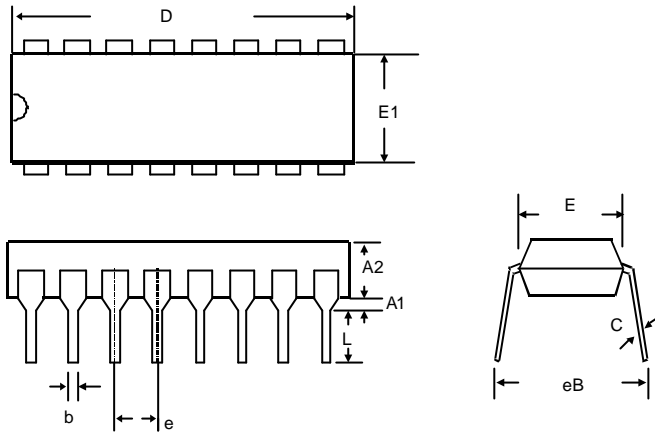

SYMBOL	MIN	MAX
A1	0.381	—
A2	2.92	4.96
b	0.35	0.56
C	0.20	0.36
D	18.66	19.69
E	7.62	8.26
E1	6.09	7.12
e	2.54(TYP)	
eB	—	10.92
L	2.92	3.81