



---

## **5-bit DAC, Synchronous PWM Power Regulator with Linear Controller**

### ■ **FEATURES**

- Switching Regulator and Low Dropout Linear Regulator on single chip.
- Simple Voltage-Mode PWM Control.
- Dual N-Channel MOSFET Synchronous Drive.
- Fast Transient Response.
- $\pm 1.0\%$  5-Bit Digital-to-Analog Output Voltage.
- Adjustable Current Limit Without External Sense Resistor.
- Full 0% to 100% Duty Ratio.
- 200KHz Free-Running Oscillator Programmable up to 350KHz.
- Power-Good Output Voltage Monitor.
- Short Circuit Protection with Low Short Circuit Output Current.
- TTL Compatible 5-bit Digital-to-Analog core Output Voltage Selection, with range from 1.3V to 3.5V;
  - 0.1V Steps from 2.0V to 3.5V
  - 0.05V Steps from 1.3V to 2.0V

### ■ **APPLICATIONS**

- Power Supply for Pentium II, Power PC and Alpha Microprocessors.
- High-Power 5V to 3.xV DC/DC Regulators.
- Low-Voltage Distributed Power Supplies.

### ■ **DESCRIPTION**

The AIC1567 is a high power, high efficiency switching regulator controller optimized for high performance microprocessor applications. It is designed to drive two N-channel MOSFETs in a standard synchronous buck topology. Featuring a low dropout linear regulator and a digitally programmable switching regulator, the AIC1567 includes monitoring and protection capabilities in addition to all the essential synchronous PWM control functions.

The internal 5-bit Digital-to-Analog Converter (DAC) adjusts the output voltage from 2.0V to 3.5V in 0.1V increments and 1.3V to 2.0V in 0.05V increments. The precision reference and voltage-mode control can provide output regulation within  $\pm 1.0\%$  over temperature and line voltage shifts.

The AIC1567 includes an internal 200KHz free-running oscillator that can be adjusted up to 350KHz. The resulting PWM duty ratio ranges from 0% to 100%. The error amplifier features a 11MHz bandwidth and 6V/ $\mu$ S slew rate, which enables high converter bandwidth for fast transient response.

## TYPICAL APPLICATION CIRCUIT

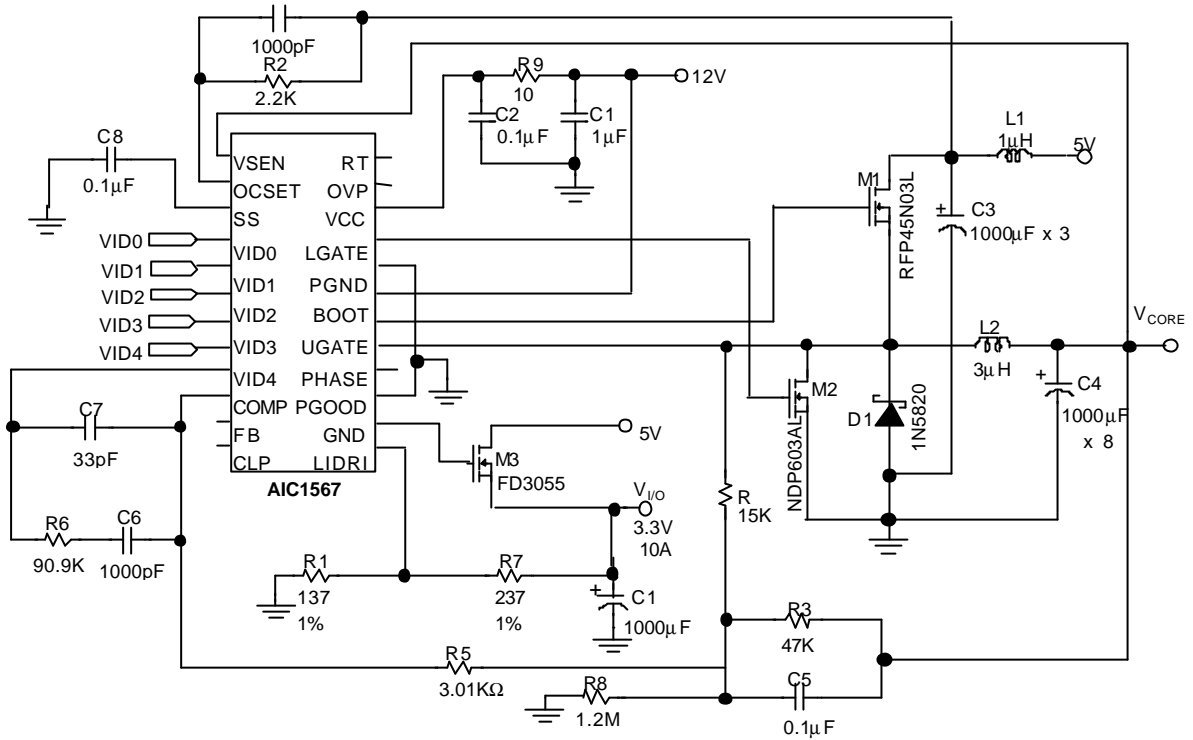

Switching DC/DC Converter

## ORDERING INFORMATION

AIC1567CXXX

- PACKING TYPE  
TR: TAPE & REEL  
TB: TUBE
- PACKAGING TYPE  
S: SMALL OUTLINE

Example: AIC1567CSTR  
→ in SO-24 Package & Taping & Reel Packing Type

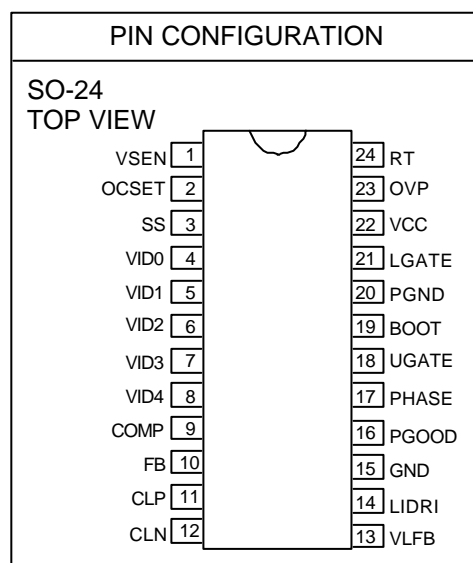

## ■ ABSOLUTE MAXIMUM RATINGS

Supply Voltage, $V_{CC}$ .....	15V
Boot Voltage, $V_{BOOT}$ .....	15V
Input, Output, or I/O Voltage .....	GND - 0.3V to $V_{CC}+0.3V$
ESD Classification .....	Class 2

### **Recommended Operating Conditions**

Supply Voltage, $V_{CC}$ .....	12V±10%
Ambient Temperature Range .....	0°C ~ 70°C
Maximum Operating Junction Temperature .....	100°C

### **Thermal Information**

Thermal Resistance, $\theta_{JA}$ (Typical, Note 1)	
SOIC Package .....	100°C/W
SOIC Package (with 3 in <sup>2</sup> of Copper) .....	90°C/W
Maximum Junction Temperature (Plastic Package) .....	150°C
Maximum Storage Temperature Range .....	-65°C~150°C
Maximum Lead Temperature (Soldering 10 sec) .....	300°C

Note 1: symbol  $q_{JA}$  is measured with the component mounted on an evaluation PC board in free air.

## ■ TEST CIRCUIT

Refer to TYPICAL APPLICATION CIRCUIT.

## ■ ELECTRICAL CHARACTERISTICS ( $V_{CC}= 12V$ , $T_A=25^\circ C$ , unless otherwise specified.)

PARAMETER	TEST CONDITIONS	SYMBOL	MIN.	TYP.	MAX.	UNIT
<b>VCC Supply Current</b>						
Nominal Supply	UGATE Open	$I_{VCC}$		2		mA
<b>Power-On Reset</b>						
$V_{CC}$ Threshold	$V_{OCSET}=4.5V$			7	8.5	V
Rising $V_{OCSET}$ Threshold				1.26		V
<b>Oscillator</b>						
Free Running Frequency	$R_T$ Open		170	200	230	KHz
Total Variation	$6K\Omega < R_T < 200K\Omega$		-20		+20	%
Ramp Amplitude	$R_T$ Open	$\Delta V_{OSC}$		1.5		$V_{P-P}$

**ELECTRICAL CHARACTERISTICS (Continued)**

PARAMETER	TEST CONDITIONS	SYMBOL	MIN.	TYP.	MAX.	UNIT
<b>Reference and DAC</b>						
DACOUT Voltage Accuracy	$V_{DAC}=1.8V \sim 3.5V$		-1.0		+1.0	%
<b>Error Amplifier</b>						
DC Gain				76		dB
Gain-Bandwidth Product		GBW		11		MHz
Slew Rate		SR		6		V/ $\mu$ S
<b>Gate Driver</b>						
Upper Gate Source		$R_{UGATE}$		8.0	12	$\Omega$
Upper Gate Sink		$R_{UGATE}$		5.5	10	$\Omega$
Lower Gate Source		$R_{LGATE}$		8.0	12	$\Omega$
Lower Gate Sink		$R_{LGATE}$		5.5	10	$\Omega$
<b>Protection</b>						
Over-Voltage Trip ( $V_{SEN/DACOUT}$ )			106	115	125	%
OCSET Current Source	$V_{OCSET}=4.5VDC$	$I_{OCSET}$	170	200	230	$\mu$ A
OVP Sourcing Current	$V_{VSEN}=5.5V, V_{OVP}=0V$	$I_{OVP}$	30			mA
Soft Start Current		$I_{SS}$		10		$\mu$ A
Soft Start Sink Current under Current Limit	$V_{VSEN}=V_{DAC}, V_{OCSET}=5.0V,$ $V_{PHASE}=0V,$ $V_{FB}=VDAC=50mV$			130		$\mu$ A
Soft Start Sink Current under Hard Current Limit	$V_{VSEN}=0, V_{OCSET}=5.0V,$ $V_{PHASE}=0V, V_{FB}=0V$			65		mA
<b>Power Good</b>						
Upper Threshold ( $V_{VSEN}/V_{DAC}$ )	$V_{VSEN}$ Rising		106		114	%
Lower Threshold ( $V_{VSEN}/V_{DAC}$ )	$V_{VSEN}$ Falling		84		94	%
Hysteresis ( $V_{VSEN}/V_{DAC}$ )	Upper and Lower Threshold			2		%
PGOOD Voltage Low	$I_{PGOOD}=5mA$	$V_{PGOOD}$		0.5		V
<b>Linear Regulator</b>						
VLFB Feedback Voltage			1.18	1.21	1.24	V
VLFB Bias Current				40		nA
LIDRI Sourcing Current			10			mA
Current Limiting Threshold			10	20	30	mV

**■ BLOCK DIAGRAM**

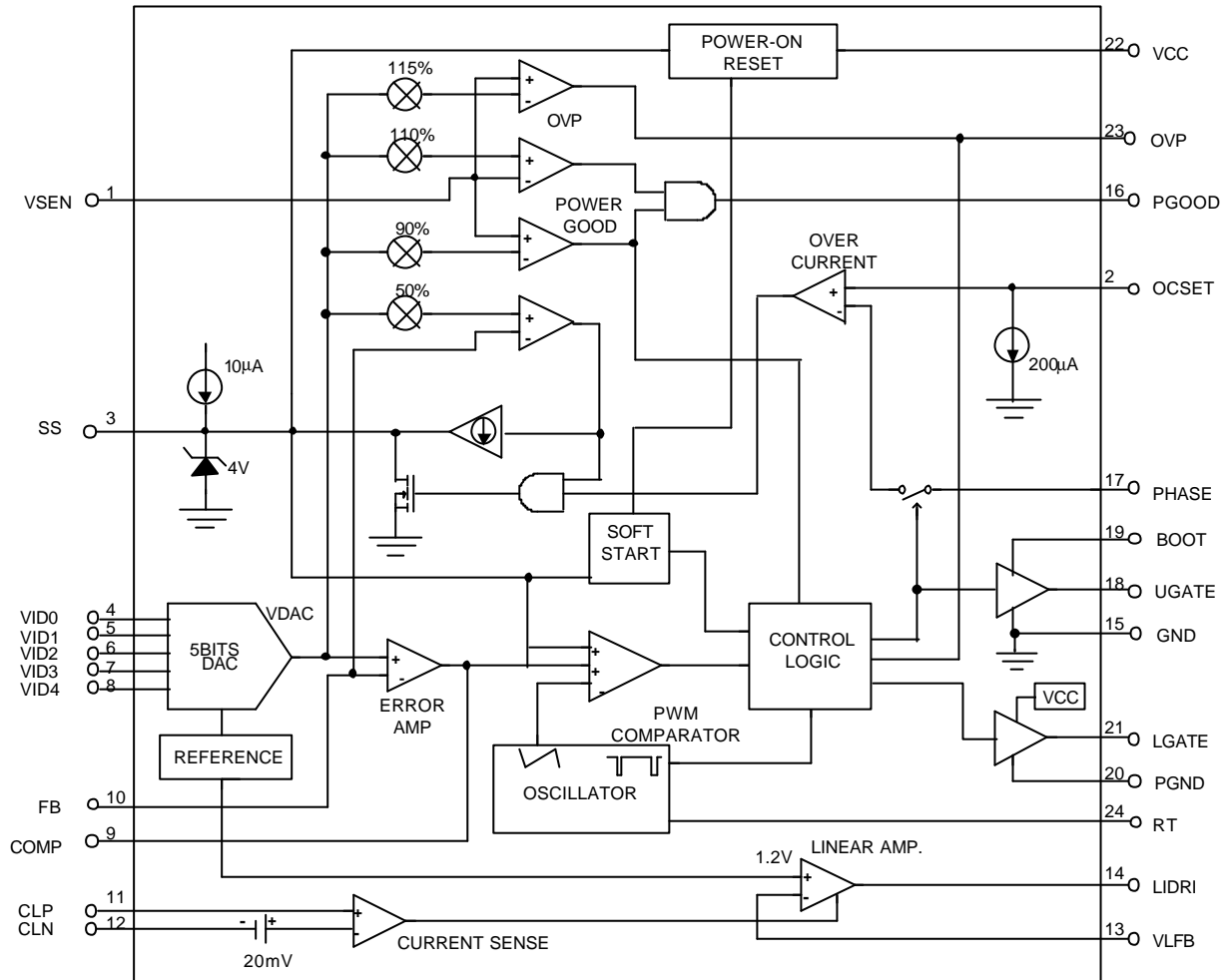

## PIN DESCRIPTIONS

**PIN 1: VSEN** - Converter output voltage sense pin. Connect this pin to the converter output. The PGOOD and OVP comparator circuits use this signal to report output voltage status and for overvoltage protection function.

**PIN 2: OCSET**- Current limit sense pin. Connect a resistor  $R_{OCSET}$  from this pin to the drain of the external MOSFET.  $R_{OCSET}$ , an internal  $200\mu A$  current source ( $I_{OCS}$ ), and the external MOSFET on-resistance ( $R_{DS(ON)}$ ) jointly set the over current trip point according to the following equation:

$$I_{PEAK} = \frac{I_{OCS} \times R_{OCSET}}{R_{DS(ON)}}$$

If FB pin voltage is sensed to be below 50% of the internal voltage reference VDAC, the over current comparator cycles the soft-start function.

**PIN 3: SS** - Soft start pin. Connect a capacitor from this pin to ground. An internal  $10\mu A$  current source provides soft start function for the converter.

**PIN 4: VID0**  
**PIN 5: VID1**  
**PIN 6: VID2**  
**PIN 7: VID3**  
**PIN 8: VID4** } - 5-bit DAC voltage select pin. TTL inputs used to set the internal voltage reference VDAC. When left open, these pins are internally pulled up to 5V and provide logic ones. The level of VDAC sets the converter output voltage as well as the PGOOD and OVP thresholds.

Table 1 specifies the VDAC voltage for the 32 combinations of DAC inputs.

**PIN 9: COMP** - External compensation pin. This pin is connected to error

amplifier output and PWM comparator. An RC network is connected to FB pin to compensate the voltage-control feedback loop of the converter.

**PIN 10: FB** - The error amplifier inverting input pin. The FB pin and COMP pin are used to compensate the voltage-control feedback loop.

**PIN 11: CLP** - Linear regulator current sense pin. This pin is the positive input of the current sense comparator.

**PIN 12: CLN** - Linear regulator current sense pin. This pin is the negative input of the current sense comparator.

**PIN 13: VLFB** - Negative feedback pin for the linear regulator error amplifier.

**PIN 14: LIDRI** - Linear regulator output drive pin. This pin can drive either a Darlington NPN or an N-channel MOSFET.

**PIN 15: GND** - Signal GND. It also serves as the power GND for the upper gate driver.

**PIN 16: PGOOD**- Power good indicator pin. PGOOD is an open drain output. This pin is pulled low when the converter output is  $\pm 10\%$  out of the VDAC reference voltage.

**Table 1. Output Voltage Program**

VID4	VID3	VID2	VID1	VID0	VDAC
1	0	0	0	0	3.5V
1	0	0	0	1	3.4V
1	0	0	1	0	3.3V
1	0	0	1	1	3.2V
1	0	1	0	0	3.1V
1	0	1	0	1	3.0V
1	0	1	1	0	2.9V
1	0	1	1	1	2.8V
1	1	0	0	0	2.7V
1	1	0	0	1	2.6V
1	1	0	1	0	2.5V
1	1	0	1	1	2.4V
1	1	1	0	0	2.3V
1	1	1	0	1	2.2V

1	1	1	1	0	2.1V
1	1	1	1	1	2.0V
0	0	0	0	0	2.05V
0	0	0	0	1	2.00V
0	0	0	1	0	1.95V
0	0	0	1	1	1.90V
0	0	1	0	0	1.85V
0	0	1	0	1	1.80V
0	0	1	1	0	1.75V
0	0	1	1	1	1.70V
0	1	0	0	0	1.65V
0	1	0	0	1	1.60V
0	1	0	1	0	1.55V
0	1	0	1	1	1.50V
0	1	1	0	0	1.45V
0	1	1	0	1	1.40V
0	1	1	1	0	1.35V
0	1	1	1	1	1.30V

**PIN 17: PHASE** - Over current detection pin. Connect the PHASE pin to source of the external MOSFET. This pin detects the voltage drop across the MOSFET  $R_{DS(ON)}$  for over-current protection.

**PIN 18: UGATE**- External MOSFET gate drive pin. Connect UGATE to gate of the external MOSFET.

**PIN 19: BOOT** - External MOSFET driver power supply pin. To convert 5V main power

to  $V_{CORE}$  power by driving N-channel MOSFET, supply voltage of no higher than 12V is recommended since the negative power terminal of the internal driver is internally tied to GND.

**PIN 20: PGND** - Driver power GND pin. PGND should be connected to a low impedance ground plane in close to lower N-MOSFET source.

**PIN 21: LGATE** - Lower N-MOSFET gate driver pin.

**PIN 22: VCC** - The chip power supply pin. It also serves as power supply for LGATE driver. Recommended supply voltage is 12V.

**PIN 23: OVP** -Over voltage indicator pin. This pin also provides a driver source current to turn on an external SCR in the event of an over voltage condition.

**PIN 24: RT** - Frequency adjustment pin. Connecting a resistor (RT) from this pin to GND, increase the frequency by the following equation.

$$F_s \cong 200\text{KHz} + \frac{5 \times 10^5}{\log R_t}$$

## ■ PHYSICAL DIMENSIONS

### ● 24 LEAD PLASTIC SO (300 mil) (unit: mm)

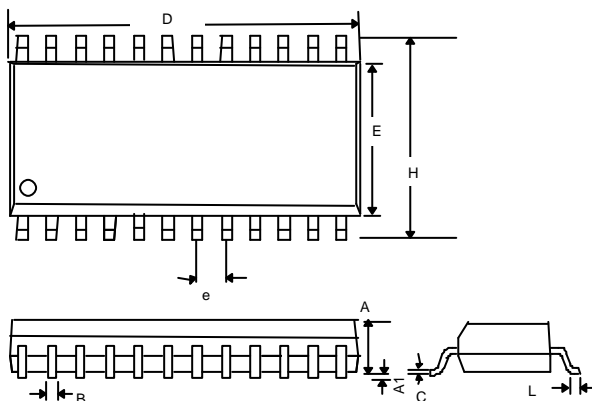

SYMBOL	MIN	MAX
A	2.35	2.65
A1	0.10	0.30
B	0.33	0.51
C	0.23	0.32
D	15.20	15.60
E	7.40	7.60
e	1.27(TYP)	
H	10.00	10.65
L	0.40	1.27