

# Low Voltage Step-Up DC/DC Controller

## FEATURES

- A Guaranteed Start-Up from less than 0.9 V.
- High Efficiency.
- Low Quiescent Current.
- Fixed or adjustable Output Voltage.
- Logic Controlled Shutdown.
- External Switch Driver for High Power Level Application.

## APPLICATIONS

- Pagers.
- Cameras.
- Wireless Microphones.
- Pocket Organizers.
- Battery Backup Suppliers.
- Portable Instruments.

## DESCRIPTION

The AIC1641 is a high efficiency step-up DC/DC controller for applications using 1 to 4 battery cells. Only three external components are required to deliver a fixed output voltage of 2.7V, 3.0V, 3.3V, or 5.0V.

Pulse Frequency Modulation scheme brings optimized performance for applications with light output loading and low input voltage. The output ripple and noise are lower compared with the circuit operating in PSM mode. The AIC1641 starts up from less than 0.9V input to boost either 2.7V, 3.0V, 3.3V, or 5.0V output with 1mA load.

Shutdown mode is one of the features that may prolong the battery service time. The PFM control circuit operates in 100KHz (max.) switching rate, resulting in smaller passive component size, which makes the AIC1641 an ideal, choice of DC/DC converter for space conscious applications.

## TYPICAL APPLICATION CIRCUIT

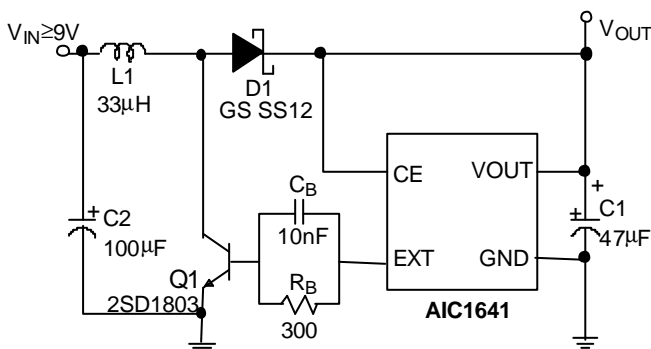

**One Cell Step-Up DC/DC Converter with Fixed Output Voltage**

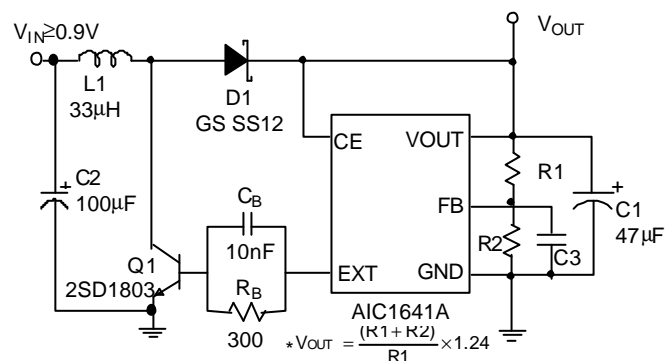

**One Cell Step-Up DC/DC Converter with Adjustable Output Voltage**

## ORDERING INFORMATION

AIC1641-XXCXXX

- PACKING TYPE  
TR: TAPE & REEL  
TB: TUBE
- PACKAGE TYPE  
O: MSOP8  
S: SMALL OUTLINE
- OUTPUT VOLTAGE  
27: 2.7V  
30: 3.0V  
33: 3.3V  
50: 5.0V  
A: Adjustable

Example: AIC1641-27COTR  
 → 2.7V Version, in MSOP8 Package  
 & Tape & Reel Packing Type

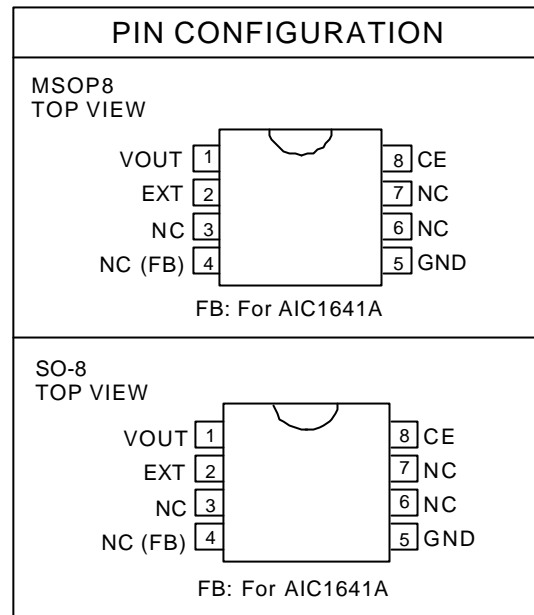

## ABSOLUTE MAXIMUM RATINGS

Supply Voltage (VOUT Pin)	.....	12V
CE input Voltage	.....	12V
FB Pin Voltage	.....	12V
EXT Pin Voltage	.....	-0.3V to Vout+0.3V
EXT Pin Current	.....	± 50mA
Operating Temperature Range	.....	-40°C to 85°C
Storage Temperature Range	.....	-65°C to 150 °C
Lead Temperature (Soldering 10 Sec.)	.....	260°C

## TEST CIRCUIT

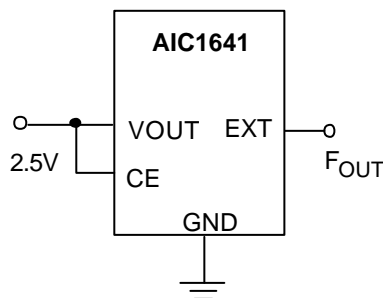

**Oscillator Test Circuit**

**ELECTRICAL CHARACTERISTICS** ( $T_A=25^\circ\text{C}$ ,  $I_{OUT}=10\text{mA}$ , Unless otherwise specified)

PARAMETER	TEST CONDITIONS	SYMBOL	MIN.	TYP.	MAX.	UNIT
Output Voltage	AIC1641-27 $V_{IN}=1.8\text{V}$	$V_{OUT}$	2.633	2.700	2.767	V
	AIC1641-30 $V_{IN}=1.8\text{V}$		2.925	3.000	3.075	
	AIC1641-33 $V_{IN}=2.0\text{V}$		3.218	3.300	3.382	
	AIC1641-50 $V_{IN}=3.0\text{V}$		4.875	5.000	5.125	
Input Voltage	Normal Operation	$V_{IN}$			8	V
Start-Up Voltage	$I_{OUT}=1\text{mA}$ , $V_{IN}:0\rightarrow 2\text{V}$	$V_{START}$		0.8	0.9	V
Hold-on Voltage	$I_{OUT}=1\text{mA}$ , $V_{IN}:2\rightarrow 0\text{V}$	$V_{HOLD}$			0.6	V
No-Load Input Current	$I_{OUT}=0\text{mA}$	$I_{IN}$		18		$\mu\text{A}$
Supply Current 1	AIC1641-27	$I_{DD1}$		45		$\mu\text{A}$
	AIC1641-30			50		
	AIC1641-33			60		
	AIC1641-50			80		
	EXT at no load, $V_{IN}=V_{OUT} \times 0.5$ Measurement of the IC input Current (VOUT Pin)					
Supply Current 2	AIC1641-27	$I_{DD2}$		7		$\mu\text{A}$
	AIC1641-30			7		
	AIC1641-33			7		
	AIC1641-50			7		
	EXT at no load, $V_{IN}=V_{OUT} + 0.5$ Measurement of the IC input Current (VOUT Pin)					
FB Reference Voltage		$V_{REF}$	1.21	1.24	1.27	V
EXT "H" On-Resistance	AIC1641-27	$R_{EXTH}$		300		$\Omega$
	AIC1641-30			200		
	AIC1641-33			185		
	AIC1641-50 $V_{EXT}=V_{OUT} - 0.4\text{V}$			130		
EXT "L" On-Resistance	AIC1641-27	$R_{EXTL}$		110		$\Omega$
	AIC1641-30			80		
	AIC1641-33			70		
	AIC1641-50 $V_{EXT}= 0.4\text{V}$			60		

**■ ELECTRICAL CHARACTERISTICS (Continued)**

PARAMETER	TEST CONDITIONS	SYMBOL	MIN.	TYP.	MAX.	UNIT
Oscillator Duty Cycle	$V_{IN}=V_{OUT} \times 0.95$ Measure the waveform at the EXT pin	DUTY	65	75	85	%
Max. Oscillator Freq.	$V_{IN}=V_{OUT} \times 0.95$ Measure the waveform at the EXT pin	F <sub>OSC</sub>	80	105	130	KHz
Chip Enable Pin Input High Voltage	AIC1641-27 AIC1641-30 AIC1641-33 AIC1641-50 $V_{IN}=V_{OUT} \times 0.95$ $V_{CEH} : 0V \rightarrow 2.5V$ Judge the oscillation at EXT pin	$V_{CEH}$	1.2 1.3 1.4 2.1			V
Chip Enable Pin Input Low Voltage	AIC1641-27 AIC1641-30 AIC1641-33 AIC1641-50 $V_{IN}=V_{OUT} \times 0.95$ $V_{CEL} : 2.5V \rightarrow 0V$ Judge the stop at EXT pin	$V_{CEL}$			1.1 1.2 1.3 2.0	V
CE Pin Input Current	Same as I <sub>DD1</sub> , $V_{CE}=V_{OUT} \times 0.95$				0.5	μA
Efficiency		η		80		%

## TYPICAL PERFORMANCE CHARACTERISTICS

Inductor (L1): 33 $\mu$ H (Pin Type)

Diode (D1): 1N5819 Schottky Type

Capacitor (C1): 47 $\mu$ F (Tantalum Type)

Transistor (Q1): 2SD1803

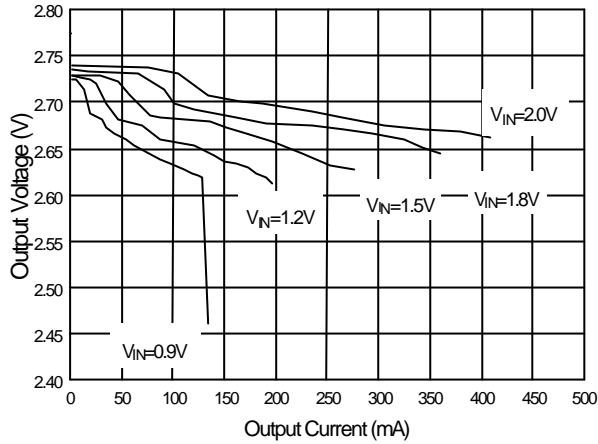

Fig. 1 AIC1641-27 Load Regulation (L=33 $\mu$ H)

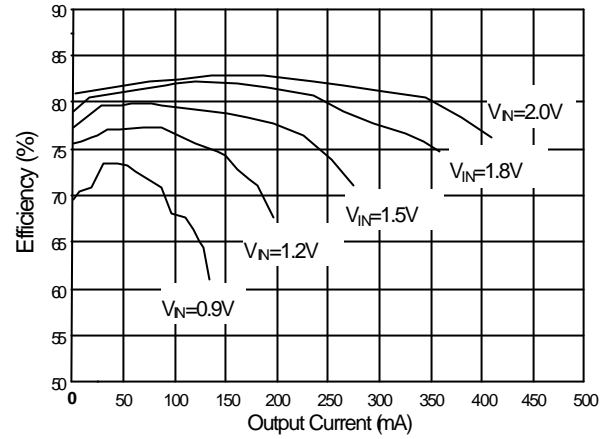

Fig. 2 AIC1641-27 Efficiency (L=33 $\mu$ H)

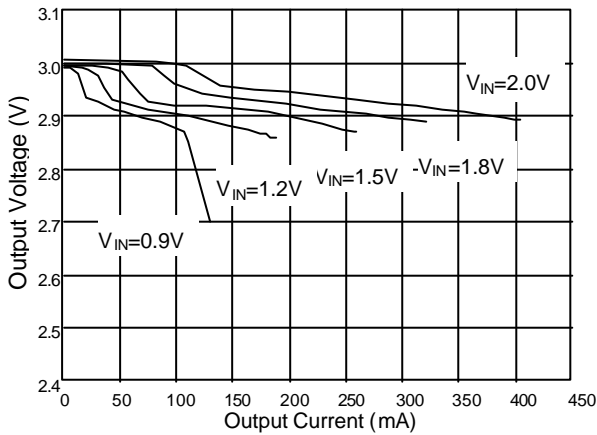

Fig. 3 AIC1641-30 Load Regulation (L=33 $\mu$ H)

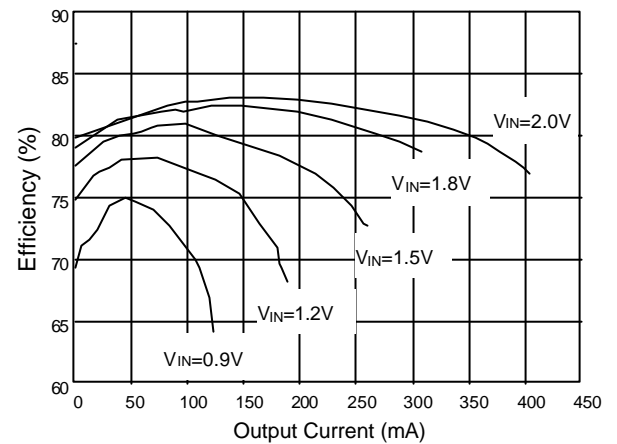

Fig. 4 AIC1641-30 Efficiency (L=33 $\mu$ H)

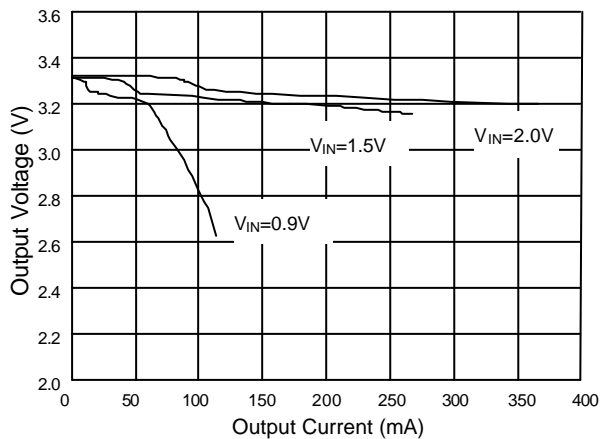

Fig. 5 AIC1641-33 Load Regulation (L=33 $\mu$ H)

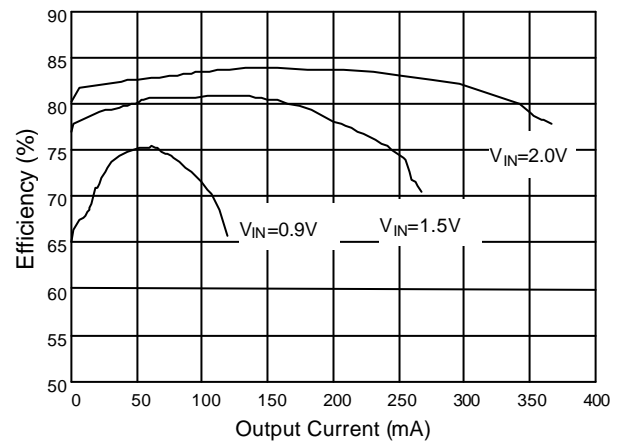

Fig. 6 AIC1641-33 Efficiency (L=33 $\mu$ H)

**TYPICAL PERFORMANCE CHARACTERISTICS (Continued)**

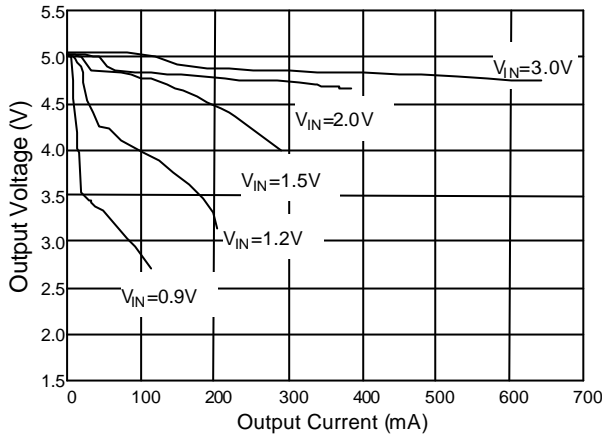

Fig. 7 AIC1641-50 Load Regulation (L=33µH)

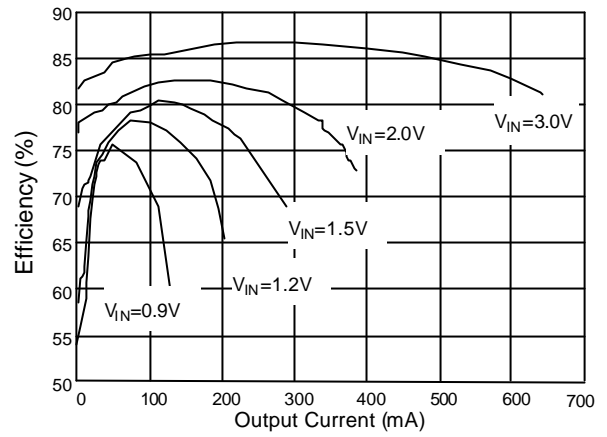

Fig. 8 AIC1641-50 Efficiency (L=33µH)

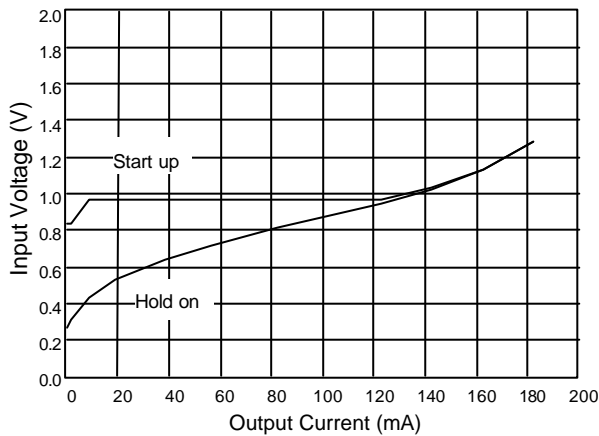

Fig. 9 AIC1641-27 Start-up & Hold-on Voltage (L=33µH)

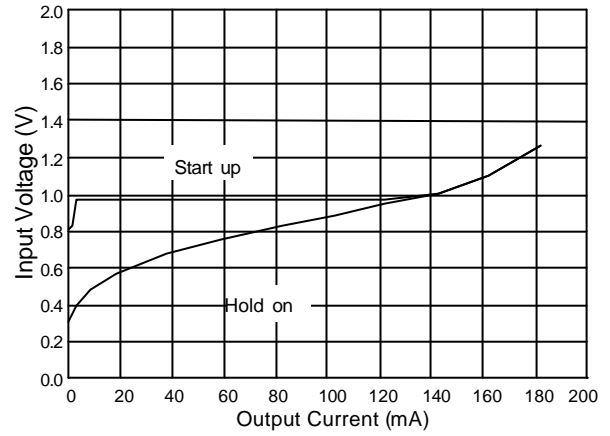

Fig. 10 AIC1641-30 Start-up & Hold-on Voltage (L=33µH)

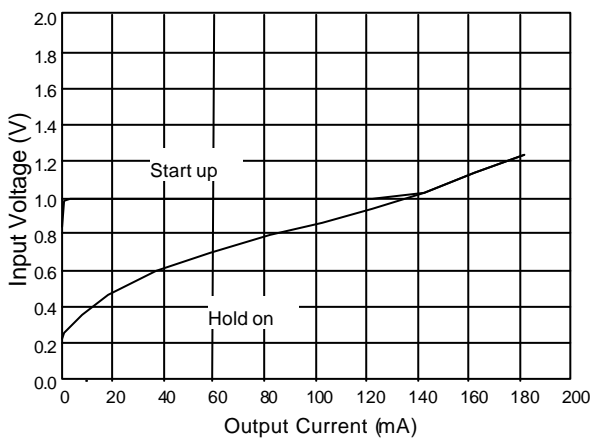

Fig. 11 AIC1641-33 Start-up & Hold-on Voltage (L=33µH)

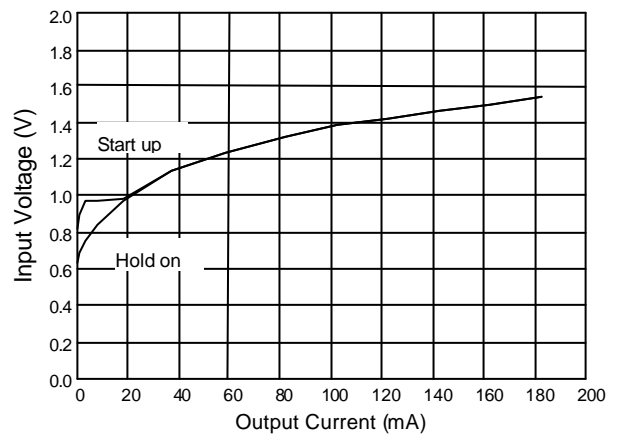

Fig. 12 AIC1641-50 Start-up & Hold-on Voltage (L=33µH)

**TYPICAL PERFORMANCE CHARACTERISTICS (Continued)**

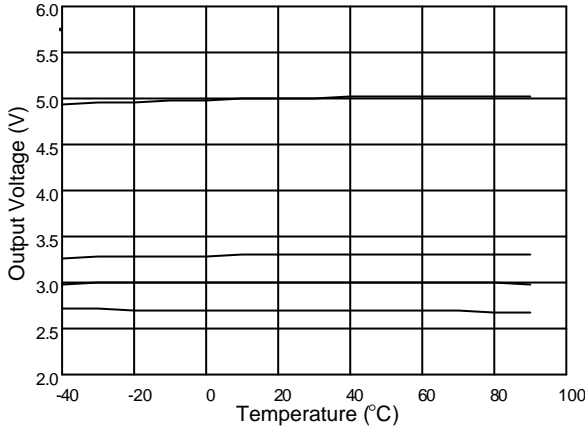

Fig. 13 AIC1641 Output Voltage vs. Temperature

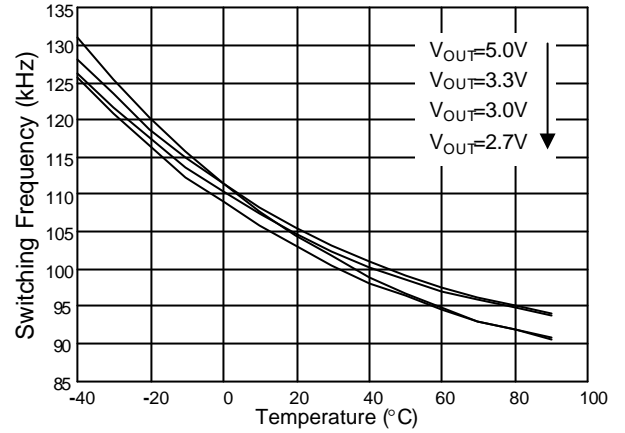

Fig. 14 AIC1641 Switching Frequency vs. Temperature

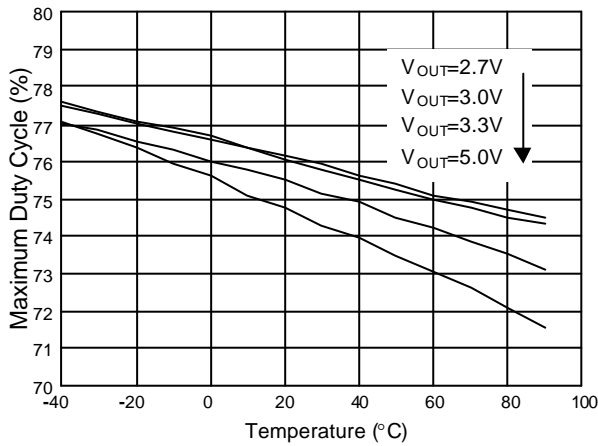

Fig. 15 AIC1641 Maximum Duty Cycle vs. Temperature

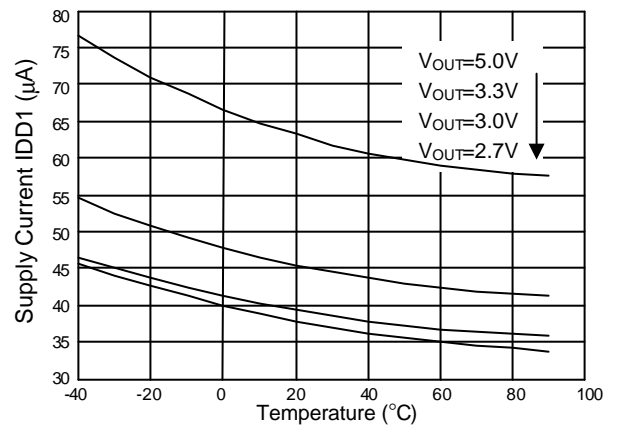

Fig. 16 AIC1641 Supply Current vs. Temperature

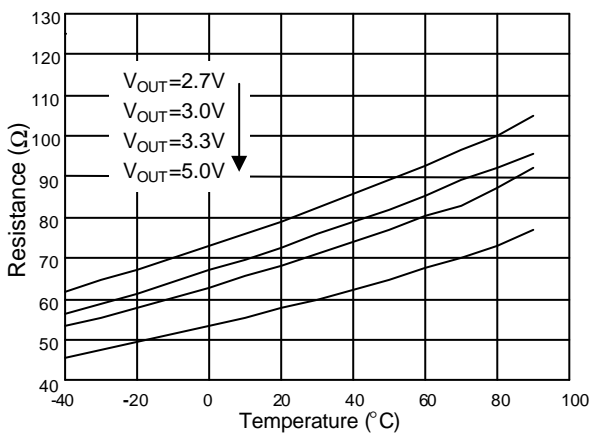

Fig. 17 AIC1641 EXT "L" On-Resistance

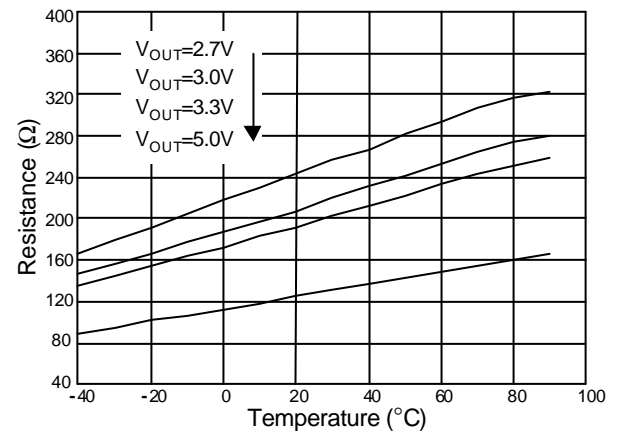
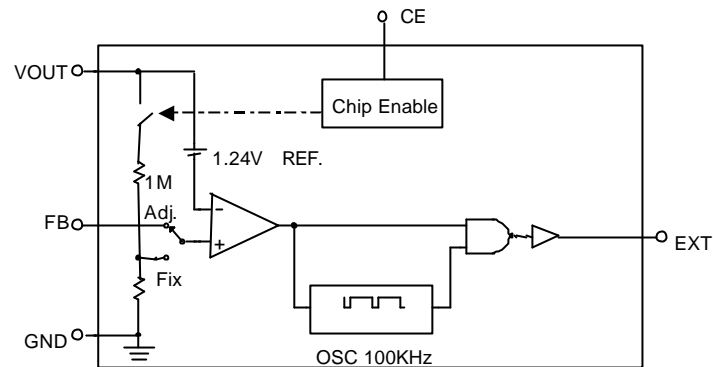
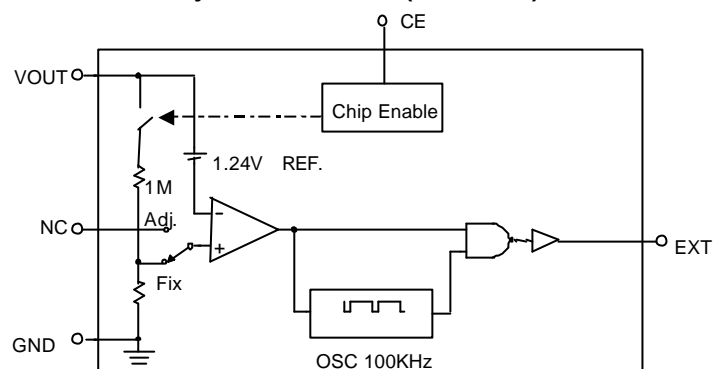

Fig. 18 AIC1641 EXT "H" On-Resistance

**BLOCK DIAGRAM**

**Adjustable Version (AIC1641A)**

**Fixed Version (AIC1641)**
**PIN DESCRIPTIONS**

NC - Not Connected.

VOUT - IC supply pin. Connect V<sub>OUT</sub> to the regulator output.

CE - Chip enable pin (Active High).

EXT - Push pull driver output for external power switch.

GND - Ground Terminal. Must be low impedance; solder directly to ground plane.

FB - Output Voltage Adjustable Pin. VOUT voltage is given by the following equation:

$$\frac{R2}{R1} = \frac{V_{OUT}}{1.24} - 1$$

## APPLICATION INFORMATION

### GENERAL DESCRIPTION

AIC1641 PFM (pulse frequency modulation) controller ICs can ensure a start-up with low battery voltage (0.8V typ.) by the three functions -- extreme low quiescent current, high efficiency, and very low gate threshold voltage -- which are provided by a switch mode regulator, push pull driver, precision voltage reference, and voltage detector in a single monolithic device. AIC1641 is designed to maximize battery life and minimize switching loss by simply switching MOSFET while load needed.

PFM controllers transfer a discrete amount of energy per cycle and regulate the output voltage by modulating switching frequency with the constant turn-on time. Switching frequency depends on load, input voltage, and inductor value, and it can range up to 100KHz.

When the output voltage drops, the error comparator enables 100kHz oscillator that turns on the MOSFET with an off-time period between 7.5 $\mu$ s and 2.5 $\mu$ s. Turning on the MOSFET allows inductor current to ramp up, storing energy in a magnetic field. Turning off MOSFET forces inductor current flowing through diode to the output capacitor and load. As the stored energy decreases tremendously, the current ramps down until the diode turns off. At this point, inductor may ring due to residual energy and stray capacitance. The output capacitor stores charge when current flowing through the diode is big, and releases it when current is small. Thereby, a steady voltage across the load can be maintained.

As the load increases, the output capacitor discharges faster and the error comparator initiates cycles sooner, increasing the switching frequency.

The maximum duty cycle ensure adequate time for energy transfer to output during the second half each cycle. Depending on circuit, PFM controller can operate in either discontinuous mode or continuous conduction mode. Continuous conduction mode means that the inductor current does not ramp to zero during each cycle.

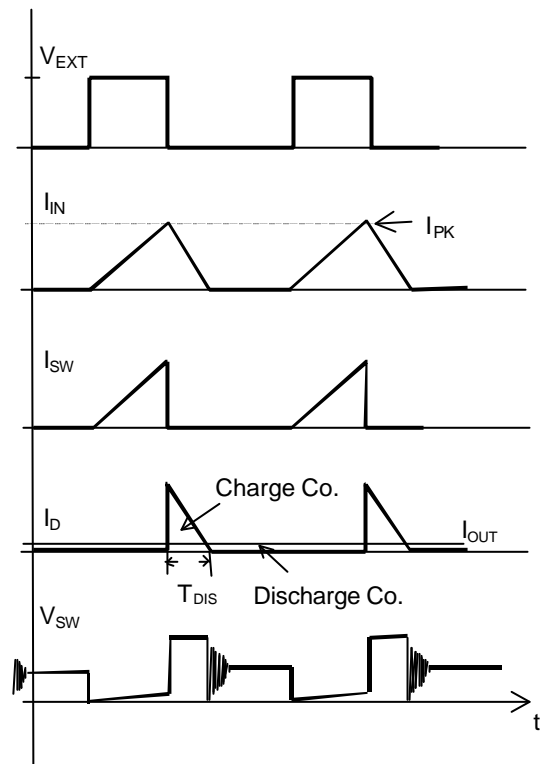
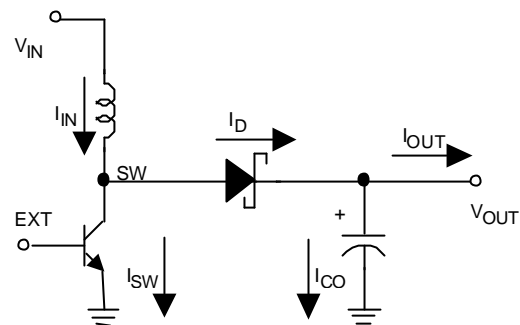

**Discontinuous Conduction Mode**

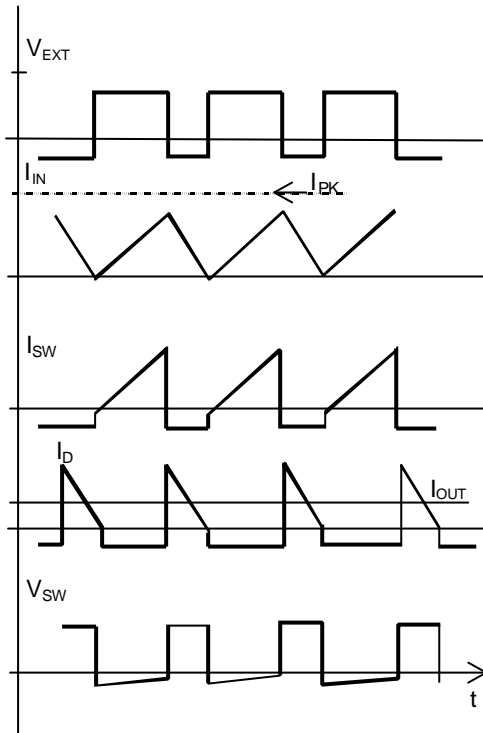

### Continuous Conduction Mode

At the boundary between continuous and discontinuous mode, output current ( $I_{OB}$ ) is determined by

$$I_{OB} = \left( \frac{V_{IN}}{V_{OUT} + V_D} \right) * \frac{1}{2} * \frac{V_{IN}}{L} * T_{ON} * (1 - x)$$

where  $V_D$  is the diode drop,

$$X = (R_{ON} + R_s) * \frac{T_{ON}}{L}$$

$R_{ON}$  = Switch turn on resistance,  $R_s$  = Inductor DC resistance

$T_{ON}$  = Switch ON time

In the discontinuous mode, the switching frequency ( $F_{sw}$ ) is

$$F_{sw} = \frac{2(L) * (V_{OUT} + V_D - V_{IN}) * (I_{OUT})}{V_{IN}^2 * T_{ON}^2} (1 + x)$$

In the continuous mode, the switching frequency is

$$f_{sw} = \frac{1}{T_{ON}} * \frac{(V_{OUT} + V_D - V_{IN})}{(V_{OUT} + V_D - V_{SW})} * \left[ 1 + \frac{x}{2} * \left( \frac{V_{IN} - V_{SW}}{V_{OUT} + V_D - V_{SW}} \right) \right] \cong \frac{1}{T_{ON}} * \left( \frac{V_{OUT} + V_D - V_{IN}}{V_{OUT} + V_D - V_{SW}} \right)$$

where  $V_{sw}$  = switch drop and proportion to output current.

### INDUCTOR SELECTION

To operate as an efficient energy transfer element, the inductor must fulfill three requirements. First, the inductance must be low enough for the inductor to store adequate energy under the worst case condition of minimum input voltage and switch ON time. Second, the inductance must also be high enough so that maximum current rating of AIC1641 and inductor are not exceeded at the other worst case condition of maximum input voltage and ON time. Lastly, the inductor must have sufficiently low DC resistance so excessive power is not lost as heat in the windings. But unfortunately this is inversely related to physical size.

Minimum and Maximum input voltage, output voltage and output current must be established before and inductor can be selected.

In discontinuous mode operation, at the end of the switch ON time, peak current and energy in the inductor build according to

$$I_{PK} = \left( \frac{V_{IN}}{R_{ON} + R_s} \right) * \left( 1 - \exp\left(-\frac{R_{ON} + R_s}{L} * T_{ON}\right) \right) \cong \left( \frac{V_{IN}}{L} \right) * (T_{ON}) * \left( 1 - \frac{x}{2} \right) \cong \frac{V_{IN}}{L} * T_{ON}$$

(simple lossless equation), where

$$X = (R_{ON} + R_s) * \frac{T_{ON}}{L}$$

$$\frac{1}{2}L \times I_{PK}^2$$

Power required from the inductor per cycle must be equal or greater than

$$\frac{P_L}{f_{SW}} = (V_{OUT} + V_D - V_{IN}) * (I_{OUT}) * \left(\frac{1}{f_{SW}}\right)$$

In order for the converter to regulate the output.

When loading is over IOB, PFM controller operates in continuous mode. Inductor peak current can be derived from

$$I_{PK} = \left( \frac{V_{OUT} + V_D - V_{SW}}{V_{IN} - V_{SW}} - \frac{X}{2} \right) * I_{OUT} +$$

$$\left( \frac{V_{IN} - V_{SW}}{2L} \right) * T_{ON} * \left( 1 - \frac{X}{2} \right)$$

Valley current (I<sub>v</sub>) is

$$I_V = \left( \frac{V_{OUT} + V_D - V_{SW}}{V_{IN} - V_{SW}} - \frac{X}{2} \right) * I_{OUT} -$$

$$\left( \frac{V_{IN} - V_{SW}}{2L} \right) * T_{ON} * \left( 1 - \frac{X}{2} \right)$$

Table 1 Indicates resistance and height for each coil.

Power Inductor Type	Inductance (mH)	Resistance (W)	Rated Current (A)	Height (mm)
Sumida SMT Type CD54	47	0.25	0.7	4.5
	100	0.50	0.5	
Hold SMT Type PM54	47	0.25	0.7	4.5
	100	0.50	0.5	
Hold SMT Type PM75	33	0.11	1.2	5.0
Huan Feng PIN Type V0810	33	40m	2	10.0

### CAPACITOR SELECTION

A poor choice for an output capacitor can result in poor efficiency and high output ripple. Ordinary aluminum electrolyzers, while inexpensive may have unacceptably poor ESR and ESL. There are low ESR aluminum capacitors for switch mode DC-DC converters which work much better than general propose unit. Tantalum capacitors provide still better performance at more expensive. OS-CON capacitors have extremely low ESR in a small size. If capacitance is reduced, output ripple will increase.

Most of the input supply is supplied by the input bypass capacitor; the capacitor voltage rating

should be at least 1.25 times greater than a maximum input voltage.

### DIODE SELECTION

Speed, forward drop, and leakage current are the three main considerations in selecting a rectifier diode. Best performance is obtained with Schottky rectifier diode such 1N5819. Motorola makes MBR0530 in surface mount. For lower output power a 1N4148 can be used although efficiency and start-up voltage will suffer substantially.

**COMPONENT POWER DISSIPATION**

Operating in discontinuous mode, power loss in the winding resistance of inductor can be approximate equal to

$$PD_L = \frac{2}{3} * \left(\frac{T_{ON}}{L}\right) * (R_s) * \left(\frac{V_{OUT} + V_D}{V_{OUT}}\right) * (P_{OUT})$$

where  $P_{OUT} = V_{OUT} * I_{OUT}$ ;  $R_s =$  Inductor DC R;

$V_D =$  Diode drop.

The power dissipated in a switch loss is

$$PD_{sw} = \frac{2}{3} * \left(\frac{T_{ON}}{L}\right) * (R_{ON}) * \left(\frac{V_{OUT} + V_D - V_{IN}}{V_{OUT}}\right) * (P_{OUT})$$

The power dissipated in rectifier diode is

$$PD_d = \left(\frac{V_D}{V_{OUT}}\right) * (P_{OUT})$$

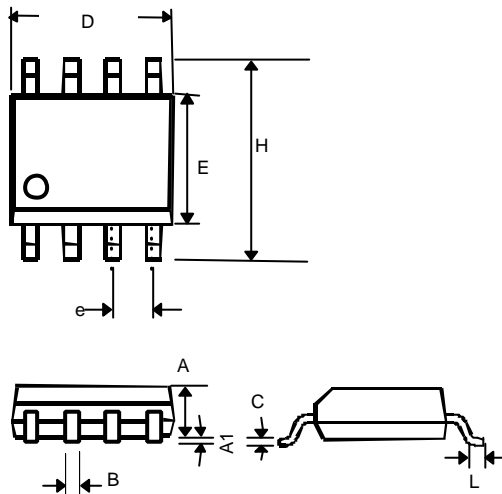
**PHYSICAL DIMENSIONS**
**● MSOP 8 (unit: mm)**

SYMBOL	MIN	MAX
A	0.76	0.97
A1	--	0.20
B	0.28	0.38
C	0.13	0.23
D	2.90	3.10
E	2.90	3.10
e	0.65	
H	4.80	5.00
L	0.40	0.66

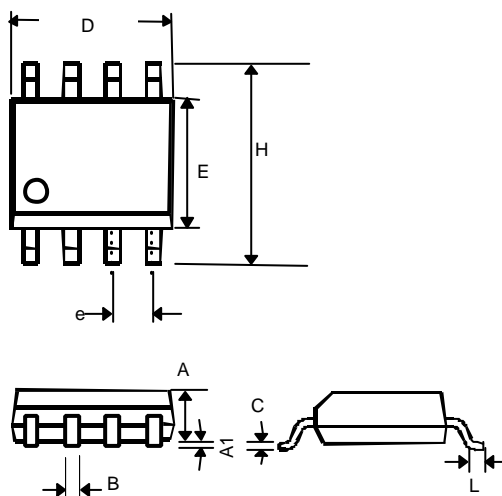
**● 8 LEAD PLASTIC SO (unit: mm)**

SYMBOL	MIN	MAX
A	1.35	1.75
A1	0.10	0.25
B	0.33	0.51
C	0.19	0.25
D	4.80	5.00
E	3.80	4.00
e	1.27(TYP)	
H	5.80	6.20
L	0.40	1.27