

500mA Low Dropout Linear Regulator

FEATURES

- Low Dropout Voltage of 750mV at 500mA Output Current (5.0V Output Version).
- Guaranteed 500mA Output Current.
- Internal 1.5Ω P-MOSFET Draws no Base Current.
- Low Ground Current: 65μA.
- 2% Accuracy Output Voltage of 3.3V/ 3.5V/ 3.7V/ 3.8V/ 5.0V/ 5.2V.
- Input Voltage Range up to 12V (5.0V Output Version).
- Needs only 4.7μF Output Capacitor for Stability.
- Current Limiting and Thermal Protection.

APPLICATIONS

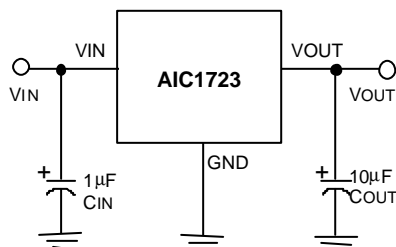
- Voltage Regulator for CD-ROM Drivers.
- Voltage Regulator for LAN Cards.
- Voltage Regulator for Monitor Microprocessor.
- Voltage Regulator for RAM Module.
- Wireless Communication Systems.
- Battery Powered Systems.

DESCRIPTION

The AIC1723 is a 3-pin low dropout linear regulator. The superior characteristics of the AIC1723 include zero base current loss, very low dropout voltage, and 2% accuracy output voltage. Typical ground current remains approximately 65μA, under the output condition of from zero up to the maximum load. Dropout voltage at 500mA output current is exceptionally low: 750mV for the AIC1723-50 and AIC1723-52, 900mV for the AIC1723-38, AIC1723-37, AIC1723-35, and the AIC1723-33. Current limiting and thermal protection are built in to protect AIC1723 against fault conditions.

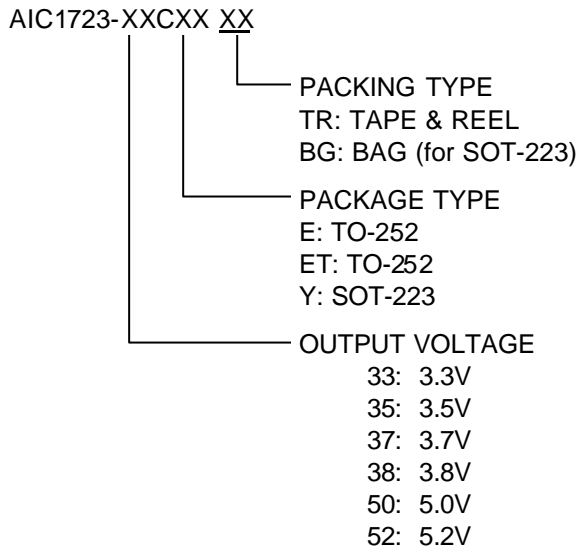
The AIC1723 comes in the popular SOT-223, and TO-252 packages.

TYPICAL APPLICATION CIRCUIT

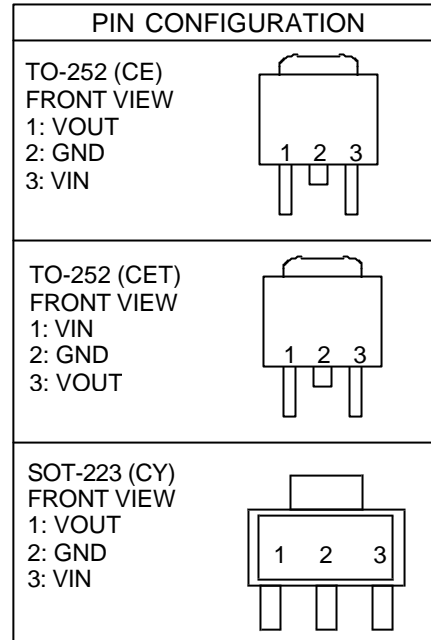


Low Dropout Linear Regulator

ORDERING INFORMATION



Example: AIC1723-33CETR
 → 3.3V Version, in TO-252 Package
 & Tape & Reel Packing Type



ABSOLUTE MAXIMUM RATINGS

Input Supply Voltage	-0.3~12V
Operating Junction Temperature Range	-40°C~ 125°C
Storage Temperature Range	-65°C~150°C
Power Dissipation	0.85W
Thermal Resistance θ_{JC}	TO-252 Package 12.5°C/W
	SOT-223 Package15°C/W
Thermal Resistance Junction to Ambient (Assume no ambient airflow, no heatsink)	TO-252 100°C/W
	SOT-223 130°C /W

TEST CIRCUIT

Refer to the TYPICAL APPLICATION CIRCUIT

■ **ELECTRICAL CHARACTERISTICS** ($T_J=25^\circ\text{C}$, $C_{IN}=1\text{mF}$, $C_{OUT}=10\text{mF}$, unless otherwise specified.)

PARAMETER	TEST CONDITIONS	MIN.	TYP.	MAX.	UNIT
Output Voltage	AIC1723-52 $V_{IN}=5.5\sim 12\text{V}$, $I_{OUT}=0\text{mA}$	5.100	5.2	5.300	V
	AIC1723-50 $V_{IN}=5.5\sim 12\text{V}$, $I_{OUT}=0\text{mA}$	4.900	5.0	5.100	
	AIC1723-38 $V_{IN}=4.7\sim 12\text{V}$, $I_{OUT}=0\text{mA}$	3.725	3.8	3.875	
	AIC1723-37 $V_{IN}=4.7\sim 12\text{V}$, $I_{OUT}=0\text{mA}$	3.625	3.7	3.775	
	AIC1723-35 $V_{IN}=4.7\sim 12\text{V}$, $I_{OUT}=0\text{mA}$	3.430	3.5	3.570	
	AIC1723-33 $V_{IN}=3.6\sim 12\text{V}$, $I_{OUT}=0\text{mA}$	3.234	3.3	3.366	
Output Voltage Temperature Coefficiency	(Note 1)		50		PPM/ $^\circ\text{C}$
Line Regulation	$I_{OUT}=1\text{mA}$				mV
	AIC1723-52 $V_{IN}=5.5\sim 12\text{V}$		3	10	
	AIC1723-50 $V_{IN}=5.5\sim 12\text{V}$		3	10	
	AIC1723-38 $V_{IN}=4.7\sim 12\text{V}$		3	10	
	AIC1723-37 $V_{IN}=4.7\sim 12\text{V}$		3	10	
	AIC1723-35 $V_{IN}=4.7\sim 12\text{V}$		3	10	
Load Regulation (Note 2)	AIC1723-52 $V_{IN}=7\text{V}$, $I_{OUT}=0.1\sim 500\text{mA}$		20	50	mV
	AIC1723-50 $V_{IN}=7\text{V}$, $I_{OUT}=0.1\sim 500\text{mA}$		20	50	
	AIC1723-38 $V_{IN}=5\text{V}$, $I_{OUT}=0.1\sim 500\text{mA}$		20	50	
	AIC1723-37 $V_{IN}=5\text{V}$, $I_{OUT}=0.1\sim 500\text{mA}$		20	50	
	AIC1723-35 $V_{IN}=5\text{V}$, $I_{OUT}=0.1\sim 500\text{mA}$		20	50	
	AIC1723-33 $V_{IN}=5\text{V}$, $I_{OUT}=0.1\sim 500\text{mA}$		20	50	
Current Limit (Note 3)	AIC1723-52 $V_{IN}=7\text{V}$, $V_{OUT}=0\text{V}$		650		mA
	AIC1723-50 $V_{IN}=7\text{V}$, $V_{OUT}=0\text{V}$		650		
	AIC1723-38 $V_{IN}=5\text{V}$, $V_{OUT}=0\text{V}$		650		
	AIC1723-37 $V_{IN}=5\text{V}$, $V_{OUT}=0\text{V}$		650		
	AIC1723-35 $V_{IN}=5\text{V}$, $V_{OUT}=0\text{V}$		650		
	AIC1723-33 $V_{IN}=5\text{V}$, $V_{OUT}=0\text{V}$		650		

ELECTRICAL CHARACTERISTICS (Continued)

PARAMETER	TEST CONDITIONS		MIN.	TYP.	MAX.	UNIT
Dropout Voltage (Note 4)	AIC1723-52	$I_{OUT}=500\text{mA}$		750	850	mV
	AIC1723-50	$I_{OUT}=500\text{mA}$		750	850	
	AIC1723-38	$I_{OUT}=500\text{mA}$		900	1050	
	AIC1723-37	$I_{OUT}=500\text{mA}$		900	1050	
	AIC1723-35	$I_{OUT}=500\text{mA}$		900	1050	
	AIC1723-33	$I_{OUT}=500\text{mA}$		900	1050	
Ground Current	$I_{OUT}=0.1\text{mA}\sim I_{MAX}$					μA
	AIC1723-52	$V_{IN}=5.5\sim 12\text{V}$		65	90	
	AIC1723-50	$V_{IN}=5.5\sim 12\text{V}$		65	90	
	AIC1723-38	$V_{IN}=4.7\sim 12\text{V}$		65	90	
	AIC1723-37	$V_{IN}=4.7\sim 12\text{V}$		65	90	
	AIC1723-35	$V_{IN}=4.7\sim 12\text{V}$		65	90	
AIC1723-33	$V_{IN}=4\sim 12\text{V}$		65	90		

Note 1: Guaranteed by design.

Note 2: Regulation is measured at constant junction temperature, using pulse testing with a low ON time.

Note 3: Current limit is measured by pulsing a short time.

Note 4: Dropout voltage is defined as the input to output differential at which the output voltage drops 100mV below the value measured with a 1V differential.

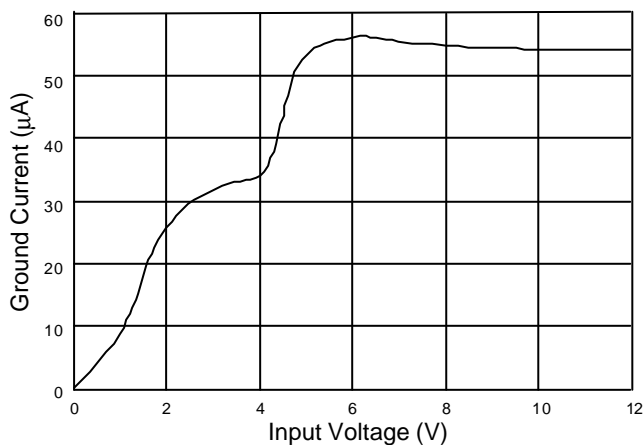
TYPICAL PERFORMANCE CHARACTERISTICS


Fig. 1 Ground Current vs. Input Voltage

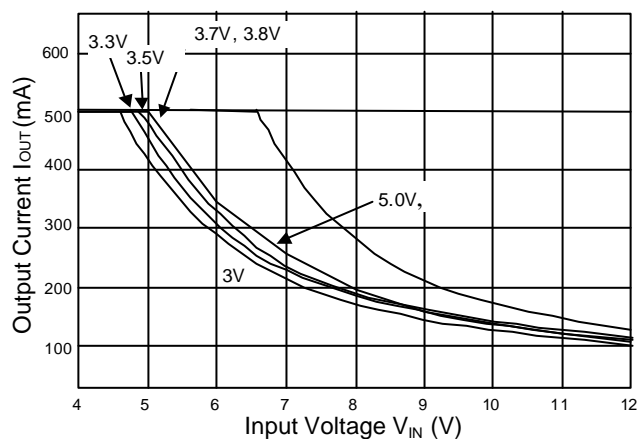


Fig. 2 Recommended Max. Output Current vs. Input Voltage

TYPICAL PERFORMANCE CHARACTERISTICS (Continued)

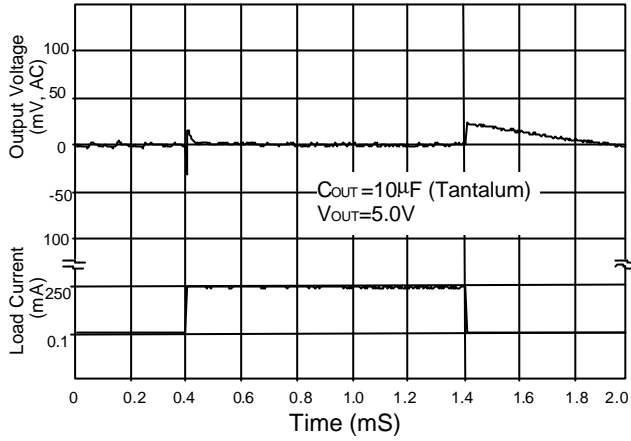


Fig. 3 Load Transient Response

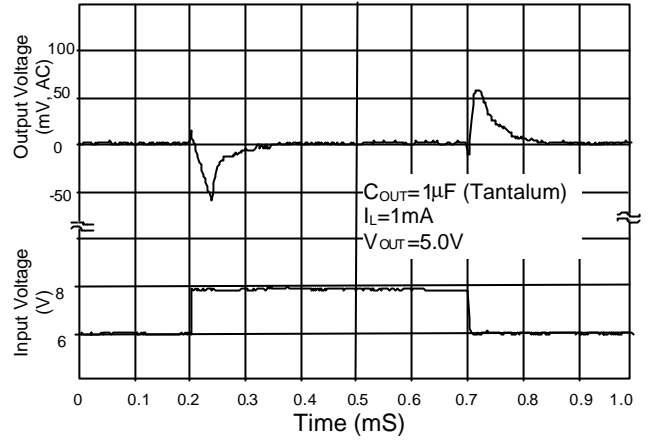


Fig. 4 Line Transient Response

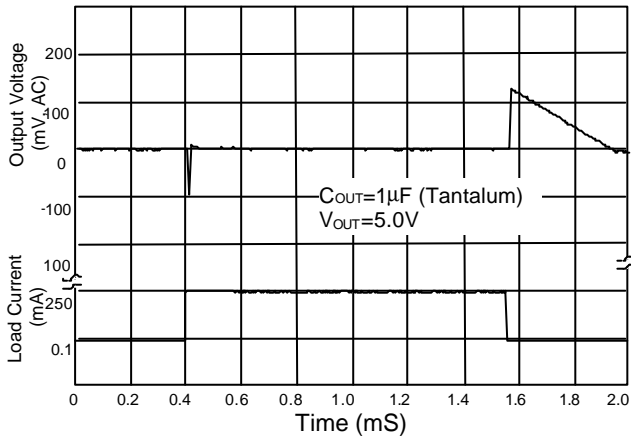


Fig. 5 Load Transient Response

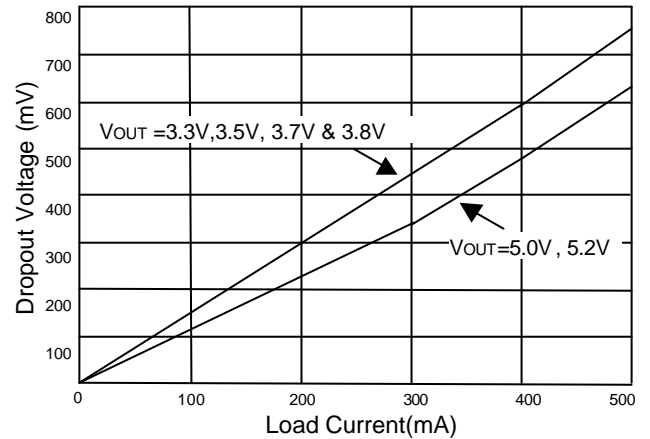
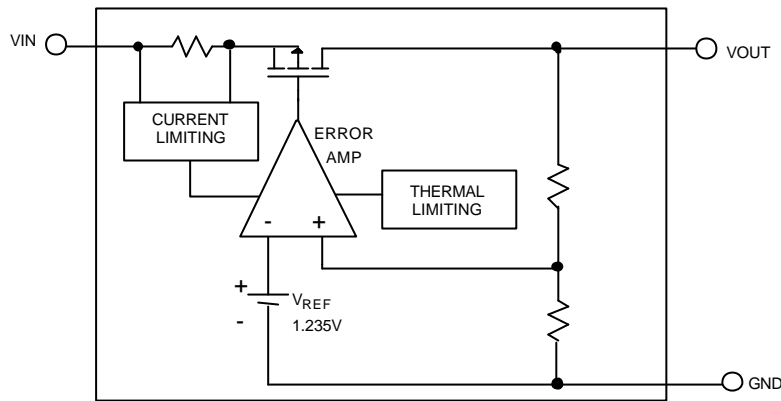


Fig. 6 Dropout Voltage vs. Load Current

■ BLOCK DIAGRAM



■ PIN DESCRIPTIONS

VOUT PIN - Output pin.

GND PIN - Power GND.

VIN PIN - Power Supply Input.

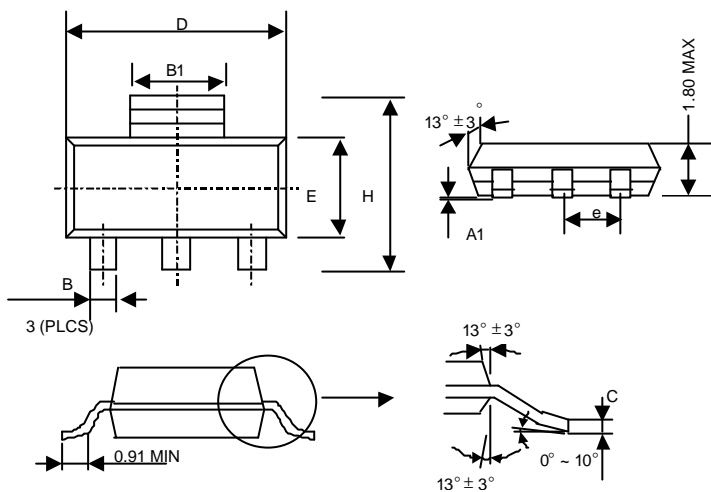
■ APPLICATION INFORMATIONS

A 4.7 μ F (or greater) capacitor is required between the AIC1723 output and ground for stability. Without this capacitor the part will oscillate. Even though most types of capacitor may work, the equivalent series resistance (ESR) should be held to 5 Ω or less if Aluminum electrolytic type is used. Many Aluminum electrolytics have electrolytes that freeze at about -30°C, so solid tantalums are recommended for operation below -25°C. The value of this capacitor may be increased without limit.

A 0.1 μ F capacitor (or greater) should be placed from the AIC1723 input to ground if the lead inductance between the input and power source exceeds 500nH (approximately 10 inches of trace).

■ PHYSICAL DIMENSIONS

● SOT-223 (unit: mm)

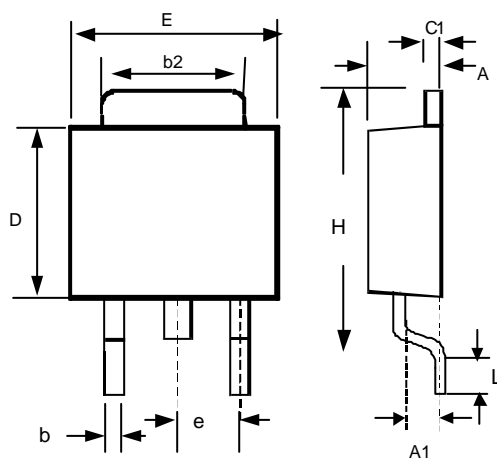


SYMBOL	MIN	MAX
A1	0.02	0.12
B	0.60	0.80
B1	2.90	3.15
C	0.24	0.35
D	6.30	6.80
E	3.30	3.70
e	2.30 (TYP.)	
H	6.70	7.30

● SOT-223 MARKING

Part No.	Marking	Part No.	Marking
AIC1723-33	AJ33	AIC1723-38	AJ38
AIC1723-35	AJ35	AIC1723-50	AJ50
AIC1723-37	AJ37	AIC1723-52	AJ52

● TO-252 (unit: mm)



SYMBOL	MIN	MAX
A	2.19	2.38
A1	1.02	1.27
b	0.64	0.88
b2	5.21	5.46
C1	0.46	0.58
D	5.33	5.59
E	6.35	6.73
e	2.28 (TYP.)	
H	9.40	10.42
L	0.51	-