

Low Output Voltage, 300mA Low Dropout Linear Regulator

FEATURES

- Low Dropout Voltage of 180mV at 100mA Output Current (3.0V Output Version).
- Guaranteed 300mA Output Current.
- Internal 1.3Ω P-MOSFET Draws no Base Current.
- Low Ground Current at 55μA.
- 2% Accuracy Output Voltage of 1.8V/ 2.0V/ 2.5V/ 2.7V/ 3.0V.
- Input Voltage Range up to 12V.
- Needs only 1μF for Stability.
- Current and Thermal Limiting.

APPLICATIONS

- Voltage Regulator for CD-ROM Drivers.
- Voltage Regulator for LAN Cards.
- Voltage Regulator for Microprocessor.
- Wireless Communication Systems.
- Battery Powered Systems.

DESCRIPTION

The AIC1737 is a 3-pin low dropout linear regulator. The superior characteristics of the AIC1737 include zero base current loss, very low dropout voltage, and 2% accuracy output voltage. Typical ground current remains approximately 55μA, from no load to maximum loading conditions. Dropout voltage is exceptionally low. Output current limiting and thermal limiting are built in to provide maximal protection to the AIC1737 against fault conditions.

The AIC1737 comes in the popular 3-pin SOT-89 packages.

TYPICAL APPLICATION CIRCUIT

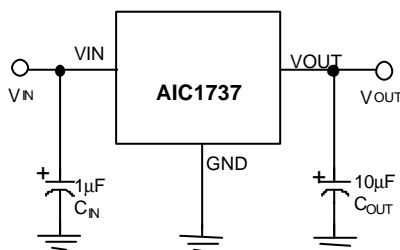

Low Dropout Linear Regulator

ORDERING INFORMATION

AIC1737-XXCXXX

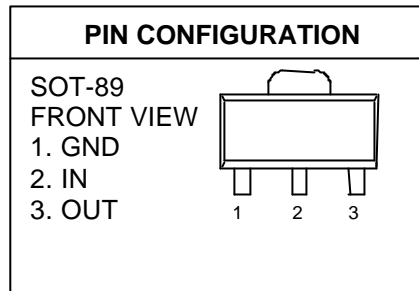
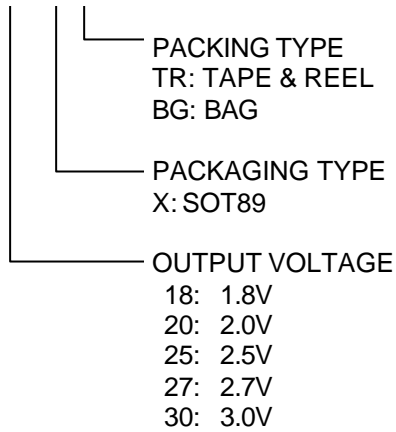

Example: AIC1737-18CXTR
 → 1.8V Version, in SOT-89 Package &
 Tape & Reel Packing Type

ABSOLUTE MAXIMUM RATINGS

Input Supply Voltage	-0.3~12V
Operating Junction Temperature Range	-40°C~ 85°C
Storage Temperature Range	-65°C~150°C
Power Dissipation	SOT-89 Package 0.5W

TEST CIRCUIT

Refer to the TYPICAL APPLICATION CIRCUIT

ELECTRICAL CHARACTERISTICS (Ta=25°C, C_{IN}=1mF, C_{OUT}=10mF, unless otherwise specified.)

PARAMETER	TEST CONDITIONS		MIN.	TYP.	MAX.	UNIT
Output Voltage	No Load					V
	AIC1737-30	V _{IN} =4.0~12V	2.940	3.000	3.060	
	AIC1737-27	V _{IN} =4.0~12V	2.646	2.700	2.754	
	AIC1737-25	V _{IN} =4.0~12V	2.550	2.500	2.550	
	AIC1737-20	V _{IN} =4.0~12V	1.960	2.000	2.040	
AIC1737-18	V _{IN} =4.0~12V	1.764	1.800	1.836		
Output Voltage Temperature Coefficiency	(Note 1)			50	150	PPM/°C
Line Regulation	I _L =1mA	V _{IN} =4.0~12V		3	10	mV
Load Regulation (Note 2)		V _{IN} =5V, I _L =0.1~300mA		7	25	mV

ELECTRICAL CHARACTERISTICS (Continued)

PARAMETER	TEST CONDITIONS		MIN.	TYP.	MAX.	UNIT
Current Limit (Note 3)	$V_{IN}=5V, V_{OUT}=0V$		320	440		mA
Dropout Voltage (Note 4)	AIC1737s	$I_L=0.1mA$		0.2	10	mV
	AIC1737-30	$I_L=300mA$		540	640	
	AIC1737-27	$I_L=300mA$		570	670	
	AIC1737-25	$I_L=300mA$		610	710	
	AIC1737-20	$I_L=300mA$		820	970	
	AIC1737-18	$I_L=300mA$		920	1070	
Ground Current	$I_O=0.1mA \sim I_{MAX}$	$V_{IN}=4 \sim 12V$		55	80	μA

Note 1: Guaranteed by design.

Note 2: Regulation is measured at constant junction temperature, using pulse testing with a low ON time.

Note 3: Current limit is measured by pulsing a short time.

Note 4: Dropout voltage is defined as the input to output differential at which the output voltage drops 100mV below the value measured with a 1V differential.

TYPICAL PERFORMANCE CHARACTERISTICS

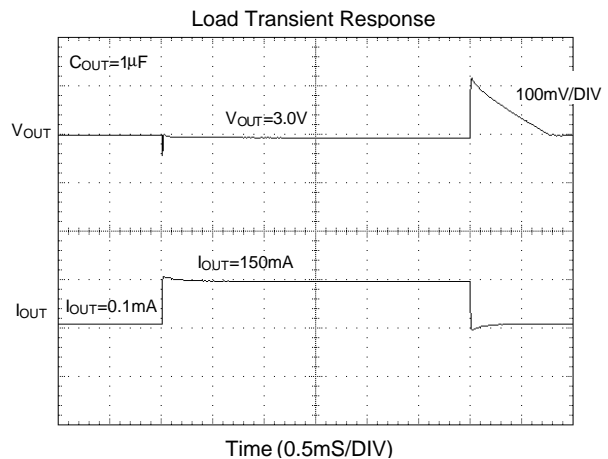
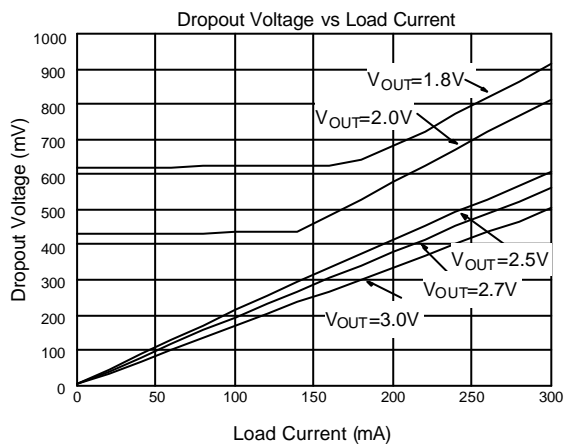

TYPICAL PERFORMANCE CHARACTERISTICS (Continued)

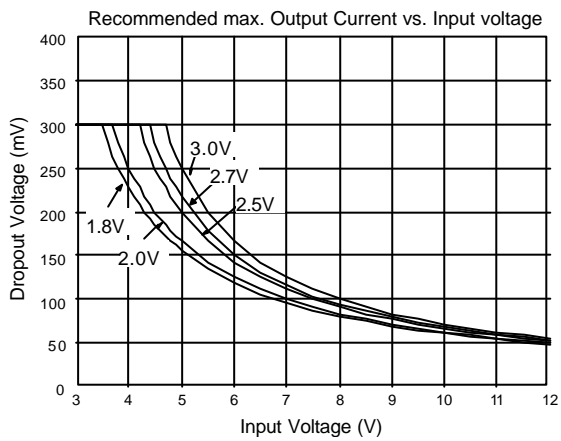
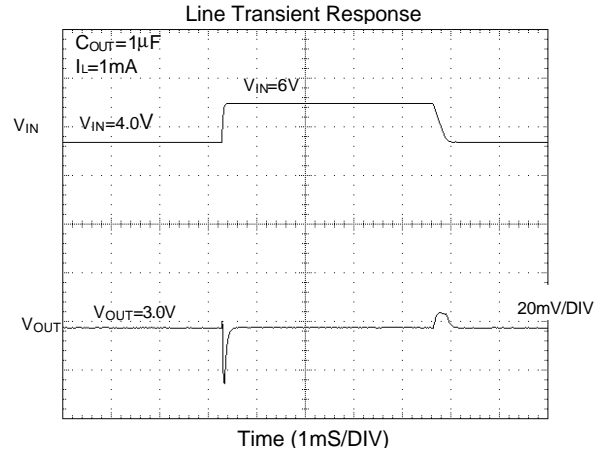
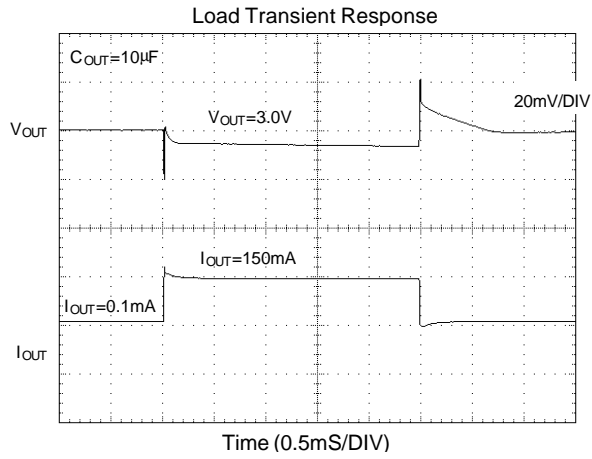

BLOCK DIAGRAM

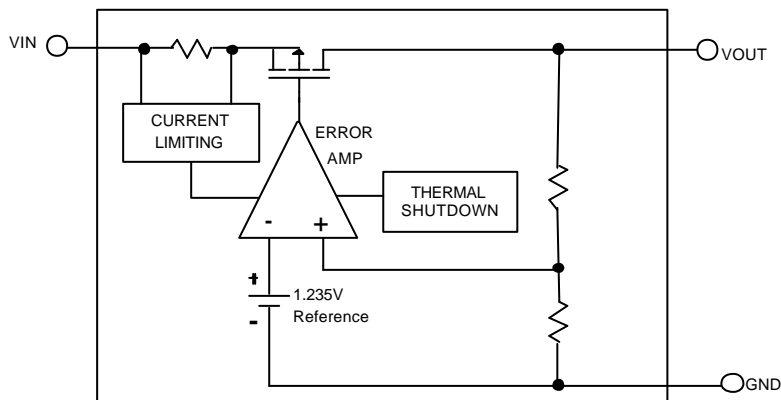

PIN DESCRIPTION

VOUT PIN - Output pin.

GND PIN - Power GND.

VIN PIN - Power Supply Input.

APPLICATION INFORMATIONS

A 1 μ F (or greater) capacitor is required between the AIC1737 output and ground for stability. Without this capacitor the part will oscillate. Even though most types of capacitor may work, the equivalent series resistance (ESR) should be held to 5 Ω or less if Aluminum electrolytic type is used. Many Aluminum electrolytics have electrolytes that freeze at about -30°C, so solid tantalums are recommended for operation below -25°C. The

value of this capacitor may be increased without limit.

A 0.1 μ F capacitor (or greater) should be placed from the AIC1737 input to ground if the lead inductance between the input and power source exceeds 500nH (approximately 10 inches of trace).

PHYSICAL DIMENSIONS

● SOT-89 (unit: mm)

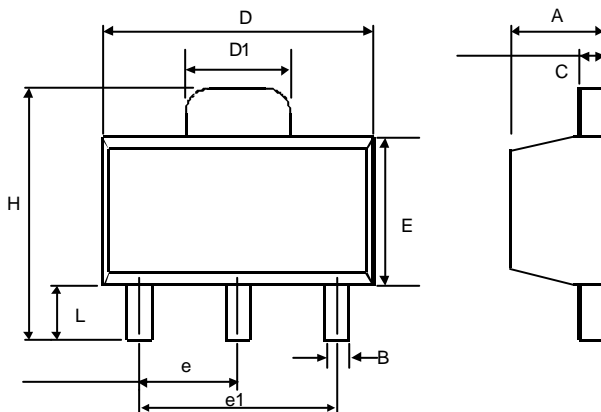

SYMBOL	MIN	MAX
A	1.40	1.60
B	0.36	0.48
C	0.35	0.44
D	4.40	4.60
D1	1.62	1.83
E	2.29	2.60
e	1.50 (TYP.)	
e1	3.00 (TYP.)	
H	3.94	4.25
L	0.89	1.20

SOT-89 MARKING

Part No.	Marking
AIC1737-18	BM18
AIC1737-20	BM20
AIC1737-25	BM25
AIC1737-27	BM27
AIC1737-30	BM30