

Battery Charge Controller for Low Power Charging

FEATURES

- Fast Charge Control of NiMH/NiCd Batteries.
- Fast Charge Termination by: $-\Delta V$, $0\Delta V$ Safety Timer, Maximum Voltage.
- Protection against Battery Voltage Fault.
- Pulsed Trickle Charge Mode.
- Quick and Easy Testing for Production.
- 8-pin DIP or SO Packages.

APPLICATIONS

Battery Fast Chargers for:

- Mobile Phones.
- Notebook and Laptop Personal Computers.
- Portable Power Tools and Toys.
- Portable Communication Equipment.
- Portable Video & Stereo Equipment.

DESCRIPTION

The AIC1783 fast charge controller IC is designed for intelligent charging of NiMH or NiCd batteries without the risk of overcharge. $-\Delta V$ detection (-0.25%) and $0\Delta V$ detection (peak voltage timer) are the primary methods employed by the AIC1783 to terminate fast charge. The fast charge can also be cut off by maximum battery voltage along with the safety timer to prevent charging under fault conditions of the charging system or the battery itself.

The safety timer period is adjustable for flexible usage that AIC1783 could be applied in the wide range of battery capacity. Test mode is provided for charger manufactures to dramatically reduce production test time.

TYPICAL APPLICATION CIRCUIT

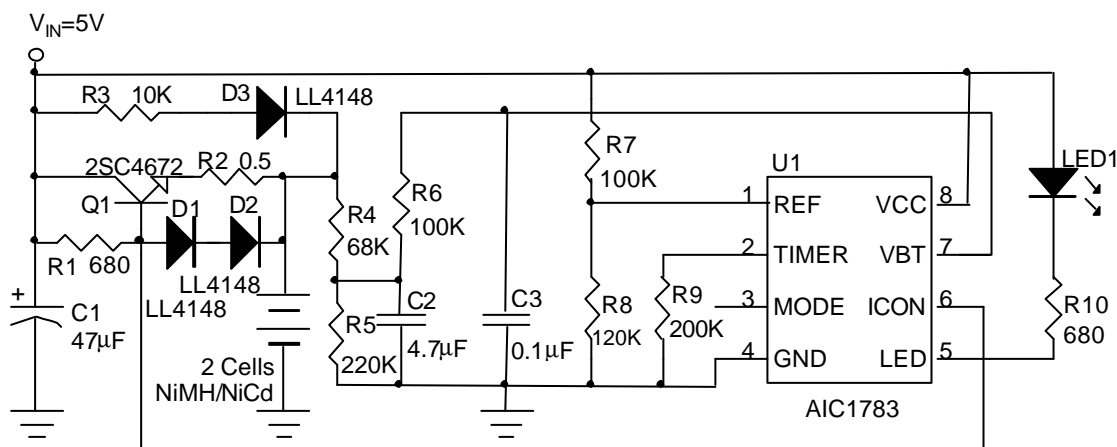

*Note: $I_{CHARGE}=380mA$ @ $V_{BAT}=2.8V$

Linear Charger for 2 Cells NiMH/NiCd Batteries

ORDERING INFORMATION

AIC1783CXXX

PACKING TYPE
 TR: TAPE & REEL
 TB: TUBE

PACKAGE TYPE
 N: PLASTIC DIP
 S: SMALL OUTLINE

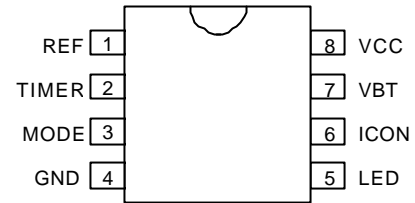
ORDER NUMBER	PIN CONFIGURATION
AIC1783CN (PLASTIC DIP)	TOP VIEW 
AIC1783CS (PLASTIC SO)	

Example: AIC1783CSTR
 → in SO-8 Package & Tape & Reel
 Packing Type
 (CN is not available in TR packing type)

ABSOLUTE MAXIMUM RATINGS

Supply Voltage	5.5V
DC Voltage Applied on any pin	5.5V
Sink current of ICON pin, LED pin	20mA
Operating Temperature Range	-40°C~ 85°C
Storage Temperature Range	-65°C~ 150°C

TEST CIRCUIT

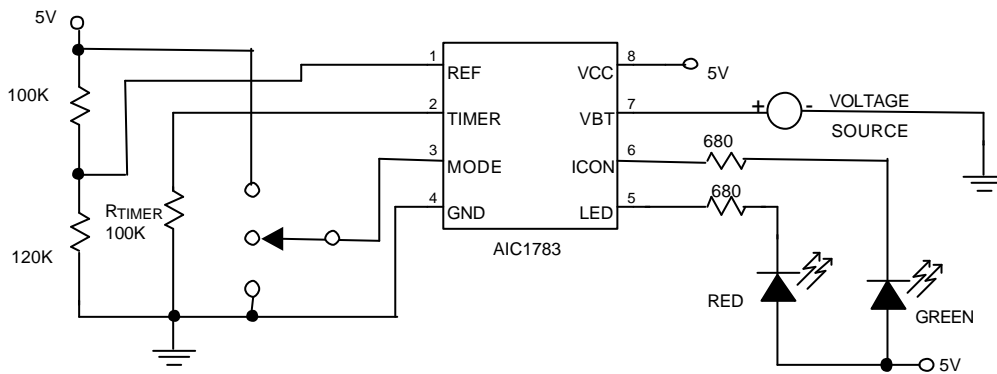

ELECTRICAL CHARACTERISTICS ($T_A=25^{\circ}\text{C}$, $V_{CC}=5\text{V}$, unless otherwise specified.)

PARAMETER	TEST CONDITIONS	SYMBOL	MIN.	TYP.	MAX.	UNIT
Supply Voltage		V_{CC}	4.5	5.0	5.5	V
Supply Current		I_{CC}		1.1		mA
Voltage Protection Limit	Battery Low During Initial Timer After Initial Timer	V_{BT}	0.11 0.63	0.16 0.69	0.21 0.75	V
	Battery High		2.6	2.7	2.80	
Output Impedance	LED, ICON Pins ON		1	25	50	Ω
	OFF			$M\Omega$		
Input Impedance	MODE pin		1	300		$K\Omega$
	VBT pin			$M\Omega$		
Recommended External Resistor of TIMER pin		R_{TIMER}	2	100	1000	$K\Omega$
$-\Delta V$ Detection accuracy	VBT=2V		-0.15	-0.25	-0.35	%

TYPICAL PERFORMANCE CHARACTERISTICS ($T_A=25^{\circ}\text{C}$, $R_{\text{TIMER}}=100\text{KW}$, $V_{\text{CC}}=5\text{V}$, refer to Test Circuit)

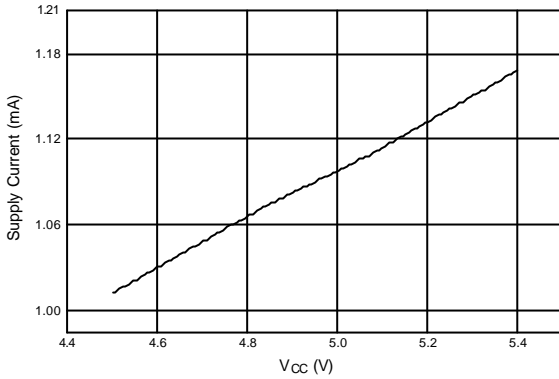

Fig. 1 Supply Current vs. Supply Voltage

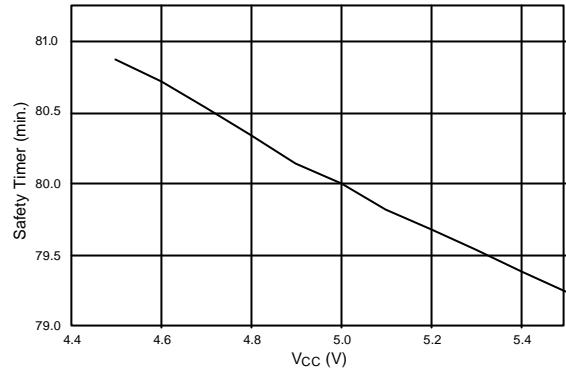

Fig. 2 Safety Timer vs. Supply Voltage

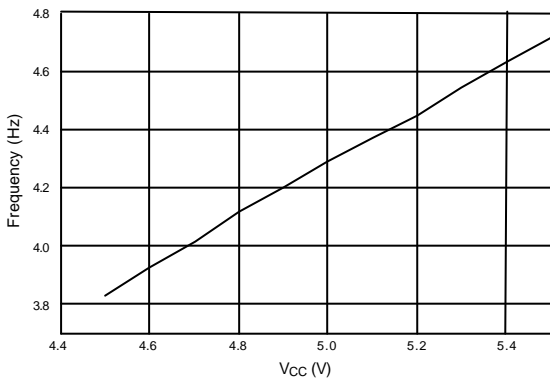

Fig. 3 LED Flashing Frequency vs. Supply Voltage

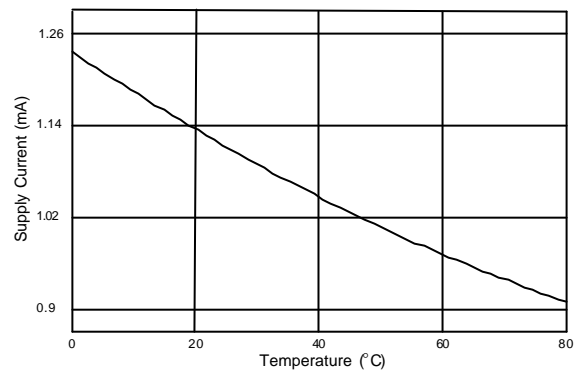

Fig. 4 Supply Current vs. Temperature

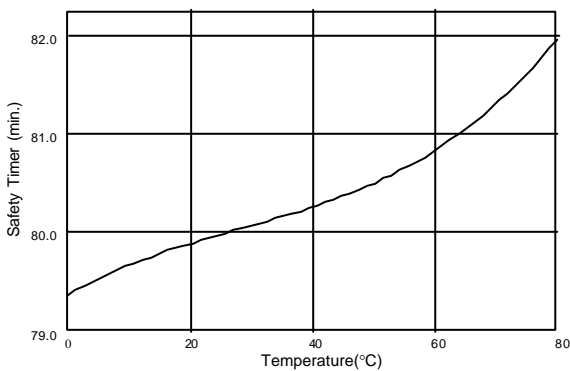

Fig. 5 Safety Timer vs. Temperature

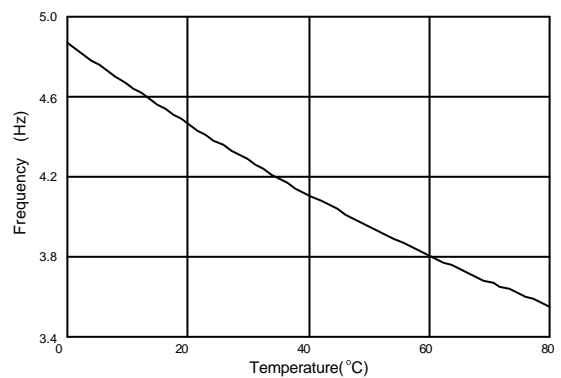

Fig. 6 LED Flashing Frequency vs. Temperature

TYPICAL PERFORMANCE CHARACTERISTICS (Continued)

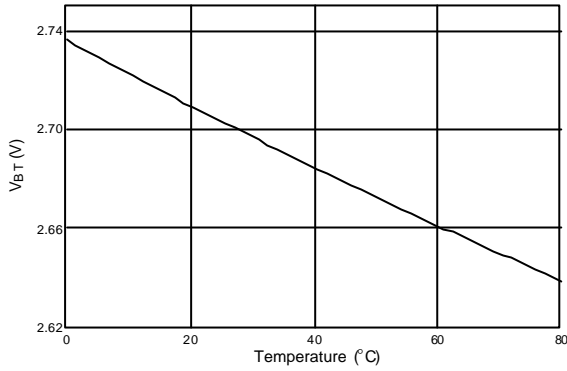

Fig. 7 V_{BT} (High) Limit vs. Temperature

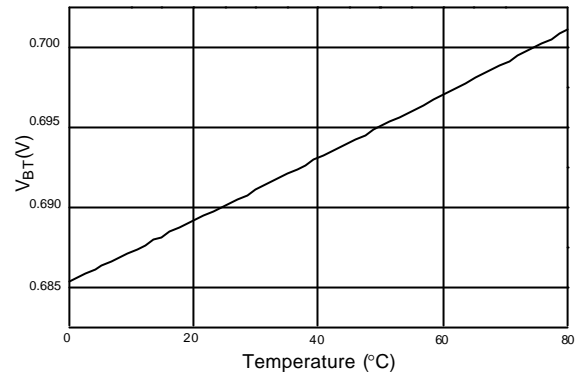

Fig. 8 V_{BT} (Low) Limit vs. Temperature (After Initial Timer)

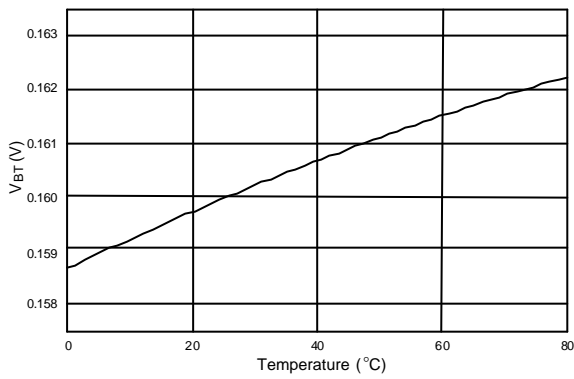

Fig. 9 V_{BT} (Low) Limit vs. Temperature (During Initial Timer)

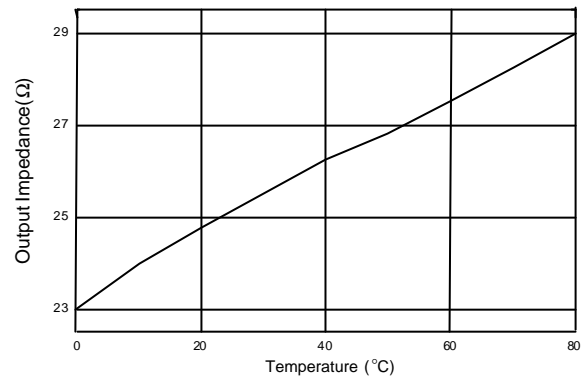
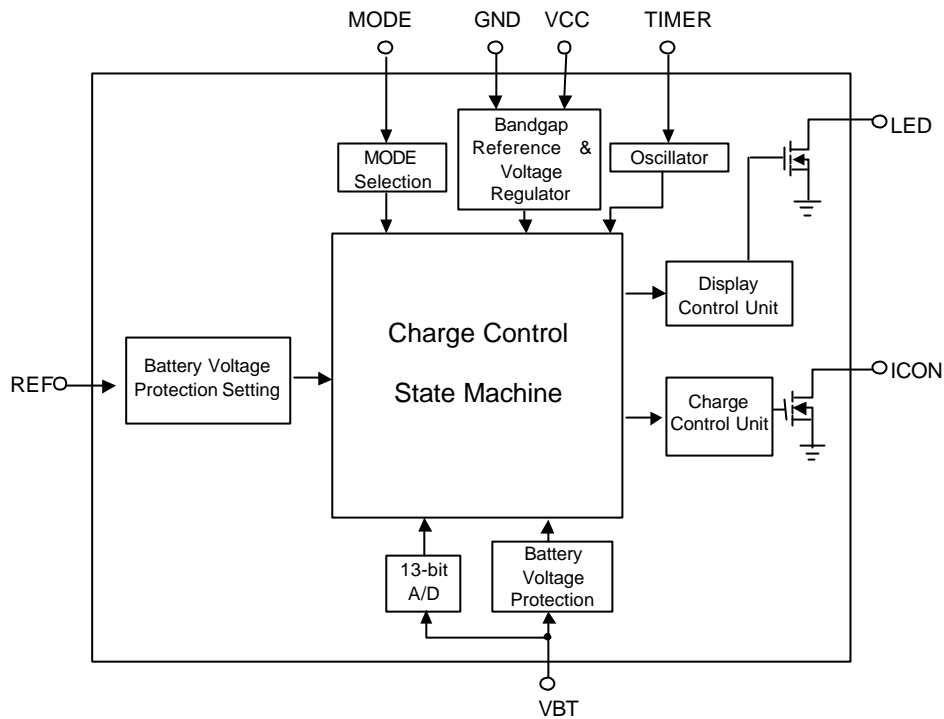

Fig. 10 Output Impedance vs. Temperature (LED, ICON pins)

■ BLOCK DIAGRAM



■ PIN DESCRIPTIONS

PIN 1: REF- Reference voltage input, acceptable voltage range :

$$(V_{CC}-1.4V) \sim (0.5V_{CC}-0.4V)$$

PIN 2: TIMER- Determining the period of safety timer with an external resistor connected to GND.

PIN 3: MODE- Determining the mode of operation for the AIC1783.

PIN 4: GND- Power ground.

PIN 5: LED- Open-drained output used to indicate the battery charging status.

PIN 6: ICON- Open-drained output, used to control the charging current to the battery.

PIN 7: VBT- Divided battery voltage input to sense the battery voltage.

PIN 8: VCC- Power supply input at $5V \pm 10\%$.

■ APPLICATION INFORMATIONS

OPERATION

Power-On and Battery Pre-qualifying

When power is first applied to the AIC1783, all internal digital circuit blocks of the AIC1783 are reset by the internal power-on-reset circuitry and output LED flash 3 times to indicate the initiation of power-on. The internal control unit then examines the battery condition through the VBT pin.

The acceptable range of VBT pin is 0.16V to 2.7V. If the voltage of VBT pin fails to fall within the predetermined acceptable limits, the AIC1783 enters a charge-suspending mode, in which all the internal circuitry remains in reset state.

Fast Charge

After the battery passes fault checks, fast charging begins while initial timer and safety timer of the AIC1783 start counting. Functions of $-\Delta V$ detection, peak voltage timer, and maximum battery voltage are, however, disabled temporarily until the initial timer period in the initial stage of a charge cycle elapses. The initial timer period is equal to 1/80 of safety timer.

Since the low limit of acceptable VBT voltage is only about 0.16V during the initial timer period, even deeply discharged batteries can easily qualify to be fast charged subsequently.

In the course of fast charge, the AIC1783 constantly monitors the voltages at VBT pin. The fast charge process is switched to trickle charge when any one of the following situations is encountered, which are explained below:

- Negative delta voltage ($-\Delta V$)
- Peak voltage timer ($0\Delta V$)

- Maximum charge time
- Maximum battery voltage

-DV Cutoff

The AIC1783 makes a voltage sampling at VBT pin every 4 seconds when safety timer period is set equal to 80 minutes. If a negative delta voltage of 0.25% compared to its peak value is detected at VBT pin, the fast charge cycle is terminated.

0DV Cutoff

If the battery voltage stays at its peak value or decreases very slowly for the duration determined by the peak voltage timer which is 6% of safety timer, the fast charge action is terminated.

Maximum Safety Timer Cutoff

The maximum fast charge period is determined by the safety timer, which is set by a resistor connected from TIMER pin to GND. Safety timer, $-\Delta V$, sampling rate will be longer if the resistor value is larger. When the value of the resistor is 100K Ω , the safety timer period equals 80 minutes. After the safety timer period is finished, the fast charge action is terminated.

Maximum Voltage Cutoff

The AIC1783 guards against the maximum limits for battery voltage during fast charging. If either of these limits is exceeded, fast charge action is terminated.

Trickle Charge

The trickle charge after the fast charge to prevent the loss of charge due to battery self-discharging. The duty cycle is set to 1/128 by internal circuitry.

The functions and charging states control mentioned above are illustrated in the function flow chart of AIC1783 (Fig. 12)

DESIGN GUIDE

Battery Voltage Measurement

The AIC1783 measures the battery voltage through VBT pin, which is connected to battery positive terminal through a resistor-divider network, as shown in Fig. 11.

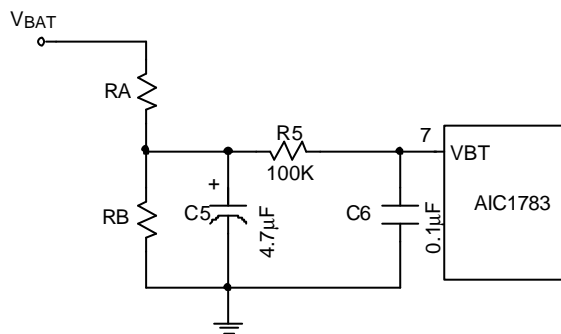

Fig. 11 Battery Voltage Divider

The suggested divider resistance of RA and RB for the corresponding number of battery cells are as below:

TABLE 1

BATTERY CELLS	RA/RB	RA (KΩ)	RB (KΩ)
2~4	2	240	120
3~6	3.3	300	91
4~8	4.9	300	62
5~10	6.4	300	47
6~12	7.8	310	39
8~16	10.8	390	36

Setting the Period of Safety Timer

The AIC1783 provides a method for linearly adjusting the period of safety timer with an external resistor connected from TIMER pin to GND. The relation between safety timer length and the external resistor (R_{TIMER}) is shown in Fig. 13. The table following shows the resistor values for some of the commonly chosen safety timer periods. Also shown in the table are their corresponding oscillator frequencies.

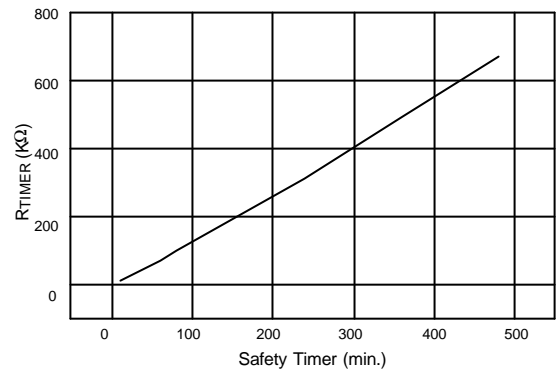

Fig. 13 Safety Timer vs. R_{TIMER}

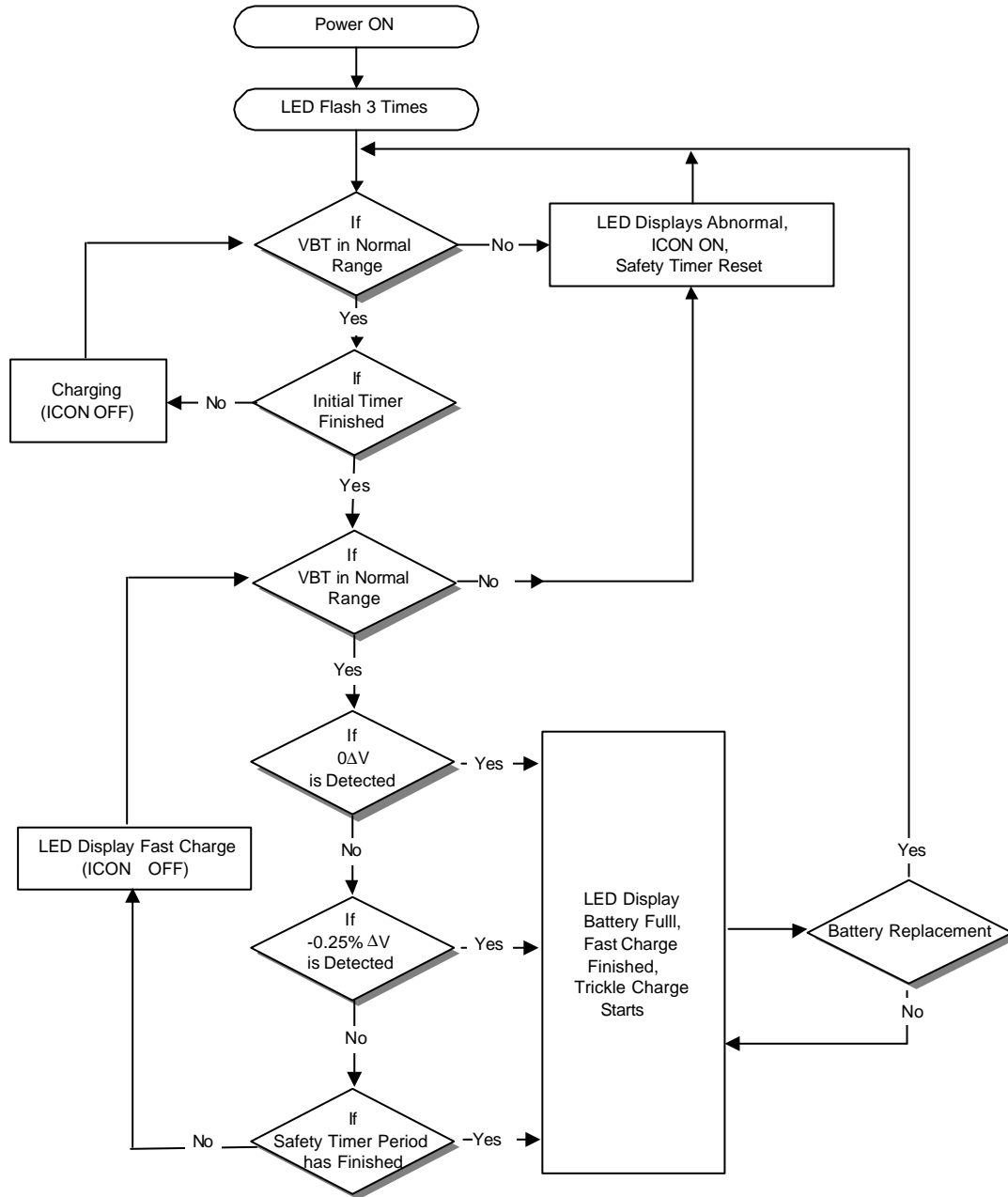

Fig. 12 Function Flow Chart of AIC1783

TABLE 2

R _{TIMER} (KΩ)	OSC. Freq.(KHz)	Safety timer (min.)
11	262.4	10
23	131.2	20
48	65.6	40
74	43.7	60
100	32.8	80
152	21.9	120
206	16.4	160
314	10.9	240
491	7.3	360
667	5.5	480

Selecting Mode of Operation

The AIC1783 provides three modes of operation: normal, test, and AC mode determined by the setting of MODE pin. The AIC1783 will operate normally when the MODE pin is left floating (a 0.1μF capacitor is recommended to be tied to MODE pin if the charge circuit works in a noisy environment). When the MODE pin is biased to GND, the function of -ΔV detection is disabled. When the MODE pin is biased to V_{CC}, the AIC1783 enters the test mode. The test mode can be used to significantly reduce production test time.

TABLE 3

MODE pin	Mode	Function
VCC	Test	Safety timer period scaled down to 1/32
Floating	Normal	Normal operation
GND	AC	-ΔV detection disabled

Display the Battery Charging Status

The AIC1783 provides an open-drained output, LED pin, to indicate the battery charging status. The outputs of LED pin are shown in the following table:

	Power ON	Fast Charging	Charge Completed	Fault Conditions
LED	1Hz	4Hz Flashing	ON	OFF

Charging Current Control

As shown in the typical application circuit, the AIC1783 offers an open-drained output pin, ICON pin, to control the charging current flow in fast charge state and switch on to inhibit the charging current flow in fault conditions. When fast charge is completed, the AIC1783 enters the trickle charge mode. In trickle charge mode, the ICON pin output switches with 1/128 duty cycle.

	Power ON	Fast Charging	Charge Completed	Fault Conditions
ICON	ON	OFF	1/128 Duty cycle	ON

APPLICATION EXAMPLE

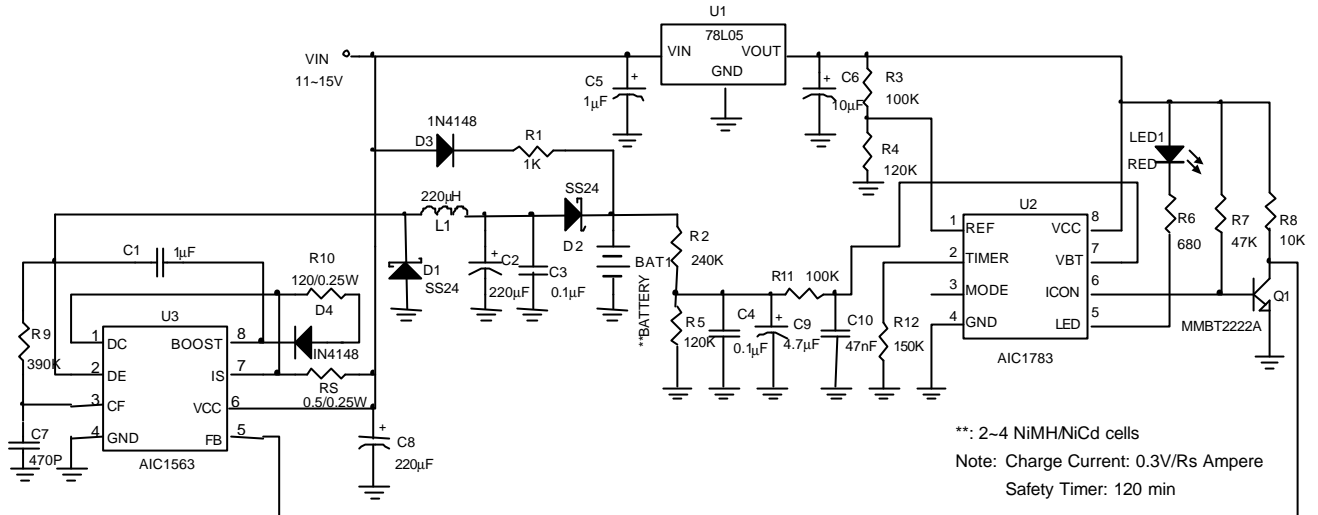
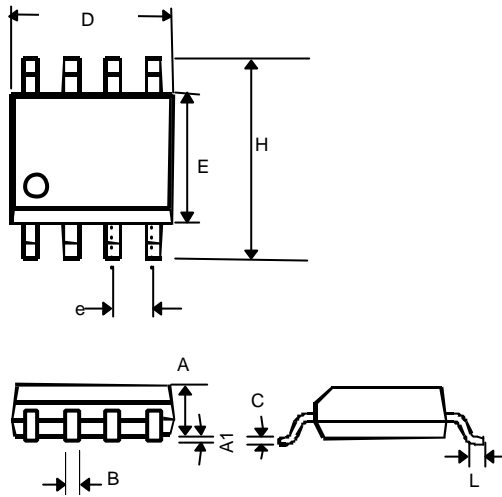

Fig. 14 Switching Battery Charger Circuit with Wide Input Voltage Range

■ PHYSICAL DIMENSIONS

- 8 LEAD PLASTIC SO (unit: mm)



SYMBOL	MIN	MAX
A	1.35	1.75
A1	0.10	0.25
B	0.33	0.51
C	0.19	0.25
D	4.80	5.00
E	3.80	4.00
e	1.27(TYP)	
H	5.80	6.20
L	0.40	1.27

- 8 LEAD PLASTIC DIP (unit: mm)

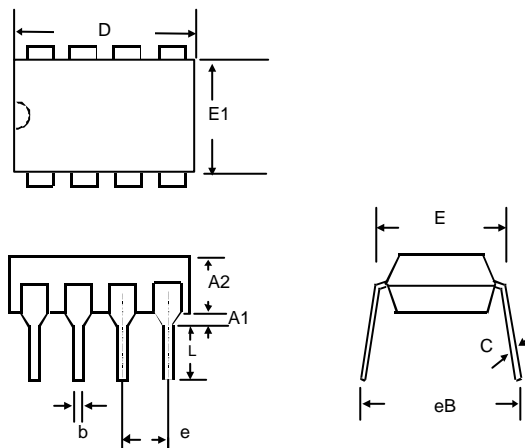

SYMBOL	MIN	MAX
A1	0.381	—
A2	2.92	4.96
b	0.35	0.56
C	0.20	0.36
D	9.01	10.16
E	7.62	8.26
E1	6.09	7.12
e	2.54 (TYP)	
eB	—	10.92
L	2.92	3.81