

Cost-Effective Power Management Design for Advanced PC Motherboards

Michael Huang

Introduction:

In such a rapidly changing information industry, it is essential to speed up the clock speed of CPU. Without increasing power dissipation, the required voltage for core part (V_{core}) in CPU such as INTEL's Pentium, Pentium II, Pentium III, AMD's K6 and K7 is keeping declining at the expense of increasing in current. To meet this requirement, the design of power converter on mother board has been changed into a Multiple Output Integrated Regulator instead of using the traditional Linear Regulator, Asynchronous Voltage Step-Down Regulator and Synchronous Voltage Step-Down Regulator. To go along with this trend, "Analog Integrations Corporation" introduces a new IC product AIC1570 that provides more integrating functions with higher performance and lower system cost.

Features of AIC1570:

The function block diagram of AIC1570 is shown in Figure 1. As illustrated, the AIC 1570 integrated type regulator consists of three different output signals from PWM Controller, Linear Controller and Linear Regulator. It provides the required voltage sources for V_{core} , GTL bus (1.5 V) and clock driver circuit (2.5 V). For PWM Controller, the device uses two N-channel MOSFET to execute a standard synchronous voltage step - down and rectification. Cooperation of this with a 5-bit DAC converter can provide an accuracy within 1% of reference voltage source (1.3 V~3.5 V) for a CPU. This product perfectly meets the voltage source requirement for INTEL and AMD's CPU.

Basic Characteristics of AIC1570:

- a. The internal free-running oscillation frequency is 200 KHz. It can be modified up to 350 KHz by adding an external resistor Rocset, if necessary.
- b. Full PWM Duty Ratio Range : 0 % ~ 100 %.
- c. The Bandwidth of PWM Error Amplifier is 11 MHz, slew rate is 6 v/ms. These can provide an excellent Transient Response.
- d. Linear Regulator can provide up to 450mA driving current.
- e. Build in perfect protection function for over-current and over-voltage.

Fundamental Operating Principle of AIC1570:

Upon an external input voltage 12 V feeding to an IC, AIC1570 starts to test and monitor three input voltage (3.3 V, 5 V and 12 V) signals sequentially by using Power On Reset (POR) function. In case any of the three input voltages exceeds the POR threshold voltage, AIC 1570 will trigger the soft start signal to accomplish a normal boot up and activate three output voltages. The essential purpose of POR is to eliminate a Special Power Sequence requirement. Therefore, AC1570 can widely work with a variety of manufacturer's Switching Power Supply (SPS).

(I) Soft Start

Objective: The PWM controller's output terminal is in parallel with many capacitors result a huge capacitance

internal conducting resistance R_{DS-ON} of MOSFET may vary with operating temperature and load current. To avoid the faulty operation of the over-current protection under normal loading, we have to consider the following factors to estimate the variables in the above formula for ideal over-current protection value:

- The maximum R_{DS-ON} at the highest junction temperature.
- The minimum I_{OCSET} from the specification table.
- Determine $I_{PEAK} > I_{OUT(MAX)} +$ (inductor ripple current) / 2

PS. It is advised to have a ceramic capacitor C_{OCSET} in paralleling with R_{OCSET} in the circuit. This can prevent the faulty operation from feeding Switching Noise interference at the input terminal.

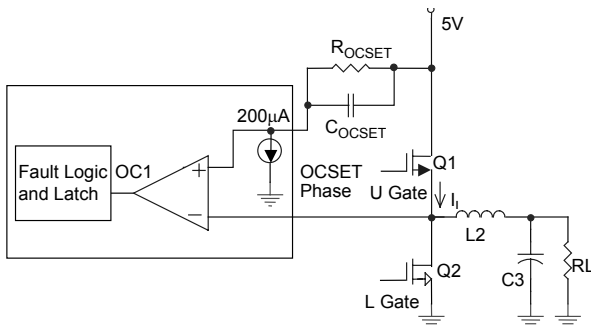

Fig. 2 Over-Current Protection Circuit

LC / LR :

Method: To set the over-current protection by using the detection of output voltage and current for LR:

- The output current can be measured by using the internal over-current detector. It is considered as over-current when the output current exceeds the specified value 500mA.
- It is considered as over-current when the monitored feedback output voltage signal level (FB2) is below the specified value

0.96V.

L.C over-current protection:

It is considered as over-current when the monitored feedback output voltage signal level (FB3) is below the specified value 0.96 V.

Working principle:

The over-current signal (OC1, OC2) can be detected when short circuit or over-current happened to any one set of the output terminals. The AIC1570 will proceed the following detection or determination operation (see Figure 3):

- Inhibit the three sets of output signal V_{CORE} , V_{GTL} and V_{CLK} .
- Reset initial signal : discharge/ charge soft-start signal.
- Increment the counter.
- Upon the soft-start signal being counted as three, AIC 1570 will trigger fault latch signal and disable the three sets of output signal.
- After the output signal being turned off, it would not restart output signals again until the removal of anomalous operation, turning-off and re-feeding 12 V voltage signal to AIC1570.

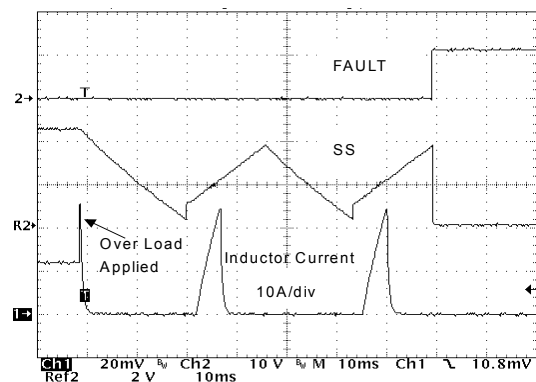

Fig. 3. Over-Curretn Operation

(III) Over-Voltage Protection

Objective: This prevents the malfunction of synchronous voltage step-down ($V_{CORE}=V_{IN}$) from the short circuit on Hi-side of MOSFET(Q1). The output

voltage may exceed the critical voltage that CPU can tolerate, which causes the CPU be destroyed.

Method: Uses V_{SEN} pin to detect the output voltage V_{CORE} of PWM. When V_{CORE} is larger than $115\%V_{DAC}$, it indicates that the output voltage is too high. AIC1570 will take the following protection: Immediately start FAULT LATCH signal allowing the switching power supply (SPS) to turn off the main voltage source (12V/ 5V/ 3.3V) on the mother board.

Low signal at U gate and high signal at L gate will force the low-side MOSFET (Q2) be conducted that leads to decreasing the PWM output voltage (V_{CORE}). An additional over-current protection at 5V input terminal is to burn out the fuse at 5V input terminal. The cutting-off voltage source at 5V input terminal would lead to $V_{CORE} \cong 0V$, which can protect CPU from being destroyed.

Selection of components: **(I) Selection of MOSFET:**

The power loss of MOSFET can be clarified as two classes: conduction losses and switching losses. Conduction losses are caused by the power loss generated by the internal conducting resistance (R_{DS-ON}) in MOSFET. In general, the temperature coefficient of R_{DS-ON} is positive because MOSFET is conducted by majority carries. In a synchronous voltage step-down circuit (BUCK), the conduction losses are related to both R_{DS-ON} in MOSFET and the duty cycle of components.

Conduction power loss at synchronous voltage step-down circuit (BUCK):

$P_{CU} = I_{OUT}^2 \times R_{DS-ON} D$ (Conduction losses on upper side of MOSFET)

$P_{CL} = I_{OUT}^2 \times R_{DS-ON} (1-D)$ (Conduction losses on lower side of MOSFET)

Switching losses : Upon MOSFET executes ON/OFF state switching, the overlapping of V_{DS}

and I_D would generate power losses. Its value is determined by input voltage, output load current and switching frequency.

Switching power losses at synchronous voltage step-down circuit (BUCK):

$P_{SU} = (I_O V_{IN} T_{SW} F)/2 + (C_{DS} V_{IN}^2 F)/2$ (Switching losses on upper side of MOSFET)

$P_{SL} = (I_O V_{IN} T_{SW} F)/2$ (Switching losses on lower side of MOSFET)

Requirement for selecting MOSFET:

- Low R_{DS-ON}
- Low C_{ISS}
- Fast Reverse recovery time
- Operating voltage and current must be in safe operating area (SOA)

(II) Selection of Schottky Diode:

There are two sets of driving circuit at synchronous voltage step-down circuit (BUCK). To avoid turning on MOSFETs on upper and lower side simultaneously, a dead-time is necessary to prevent from fatal damage. To keep output inductor current running continuously during the dead-time, it is necessary to use a free-wheeling diode to handle it. Generally speaking, the dead-time is shorter than 200 ns. It has a low efficiency drawback by using the parasitic diode on the low side MOSFET to act as free-wheeling diode, because with a large forward voltage ($V_{SD} \cong 0.9 \sim 1.3V$) and long reverse recovery time. Furthermore, they will generate a huge spike and ringing on V_{DS} of low side MOSFET. To overcome this drawback, it usually uses a Schottky Diode with low forward voltage ($\cong 0.3 \sim 0.5V$) and short reverse recovery time.

The conduction power losses of Schottky diode:
 $P_{CR} = V_F I_{OUT} (1-D)$ In which V_F is the Forward Voltage of Schottky diode.

Requirement for the selection of Schottky diode:

- a. Low V_F
- b. Low equivalent series resistance (Low ESR)
- c. Short reverse recovery time
- d. Sufficient Reverse Breakdown Voltage
- e. Sufficient peak current ($I_{D-PEAK} > I_{L-PEAK}$)

(III) Selection of input inductor and capacitor:

In a circuit application on a mother board, 5 V main power provided by an external switching power supply, not only supply the step-down low voltage source ($5V \rightarrow V_{CORE}$) for CPU but also supplies the voltage source demanded by other equipments. For a widely used synchronous voltage step-down circuit for V_{CORE} a 200KHZ switching frequency ($F_{SW}=200KHz$) is commonly adopted in PWM –6IC. An undershoot and high frequency switching noise occur on 5 V input voltage source when MOSFET is on switching. To avoid the anomalous signal influencing other equipment that can cause system unstable, it is common to have a low pass filter (type II filter) at the input terminal. The filter is composed of an inductor ($1\mu H$) in series with input capacitor. This can eliminate high frequency signal interference.

The number of input capacitor: the maximum equivalent discharge current (IIN-RMS) that is based on the requirement for application circuit determines The specification of voltage endurance on input capacitor. The maximum voltage endurance of capacitor under the highest working environment temperature should be larger than 1.2 to 1.5 times as input voltage.

(IV) Selection of the output inductor and capacitor:

In a synchronous BUCK circuit, a low pass filter, that is composed of output inductor and capacitor, can eliminate high frequency noise signal and adjust input power distributed evenly to the load. It is necessary to select the quantity and quality of output inductor and capacitor very carefully to meet

a rigorous specification of transient converting voltage (reference VRM 8.1~ 8.4 or further) on CPU required by INTEL or AMD. Inductor stores energy in terms of current. The current cannot change instantaneously but going up or down linearly. The relationships among these variables:

$$\text{Energy stored in inductor: } \omega_L = (1/2) L I^2$$

$$\text{Voltage change by inductor: } V_L = L \times di_L / dt$$

$$\text{Inductor current: } \Delta i_L = \frac{(V_{IN} - V_O)}{L} \times \Delta T$$

Suggestions to the selection of inductor:

The inductance selection should guarantee those output load would maintain working in continuous conduction mode (CCM) whether it is in heavy or light load. The higher inductance it is, the smaller output ripple voltage and slower transient response at output load would be. The actual capacitor is composed of parasitic equivalent series inductors and equivalent series resistors. The output inductor cannot provide a huge instantaneous current required by CPU immediately when the output load changes from light to heavy load abruptly (CPU MODE : Stop Grant \rightarrow Heavy Load). It must provided by output capacitor. In contrast, the output inductor cannot release excessive output current when the output load changes from heavy to light load abruptly (CPU MODE : Heavy Load \rightarrow Stop Grant). It has to be absorbed by output capacitor. Thus, it is necessary to select output capacitor carefully to meet the requirements for DC/DC CONVERTER "Transient Response" and "Static Request" specified by CPU manufacture. (INTEL or AMD)

Suggestions to the selection of capacitor:

The output capacitor should be composed of multiple small capacitors in parallel arrangement. As the number of paralleled capacitors becomes larger, the equivalent series resistance and equivalent series inductance would become smaller. If large capacitors are used instead, the output ripple voltage will become smaller. But the transient response at output load would become slower. It is a

trade-off.

Suggestions to PCB LAYOUT:

A 200KHz switching frequency is popularly used in most PWM IC (for CPU power application). The current will be charged/discharged between two configurations when upper/lower side MOSFET executes high speed ON/OFF switching states. During the states switching, the distributed inductance along the current path will generate voltage spike on switching elements. The spike voltage not only reduces the efficiency, but also produces noise signal. Worse yet it may generate over-voltage to destroy elements. Thus it needs special attention to select the proper specifications of switching elements (such as MOSFET, Diode etc.) in circuit application. Particularly, it is necessary to have a short path and wide metal trace along a path with large current on PCB layout. All of these can reduce the voltage spike.

- (1) Must use ground plane configuration. The input capacitance (C_{IN}) should be as close to power switch as possible, i.e., to shorten the current path ($C_{IN} \rightarrow Q1 \rightarrow Q2$).
- (2) To shorten and widen the current path between switching elements ($Q1 \rightarrow L \rightarrow Q2$). An EMI could be easily generated because a fast voltage transition is executed on the path.
- (3) The output capacitor (C_{OUT}) should be as close to output loading terminal (CPU) as possible. Doing so can meet the requirements for high slew rate, low inductance and low resistance.
- (4) PGND and GND of AIC1570 should be connected in a shortest path and then connected with the whole ground plane.
- (5) Compensation components for feedback signal should be configured as close as possible. To avoid interfering feedback signal with the noise signal, the components should be remote from PWM driving signal.
- (6) To be decoupled directly to GND, a $0.1\mu F$ ceramic capacitor should be placed near to VCC pin.

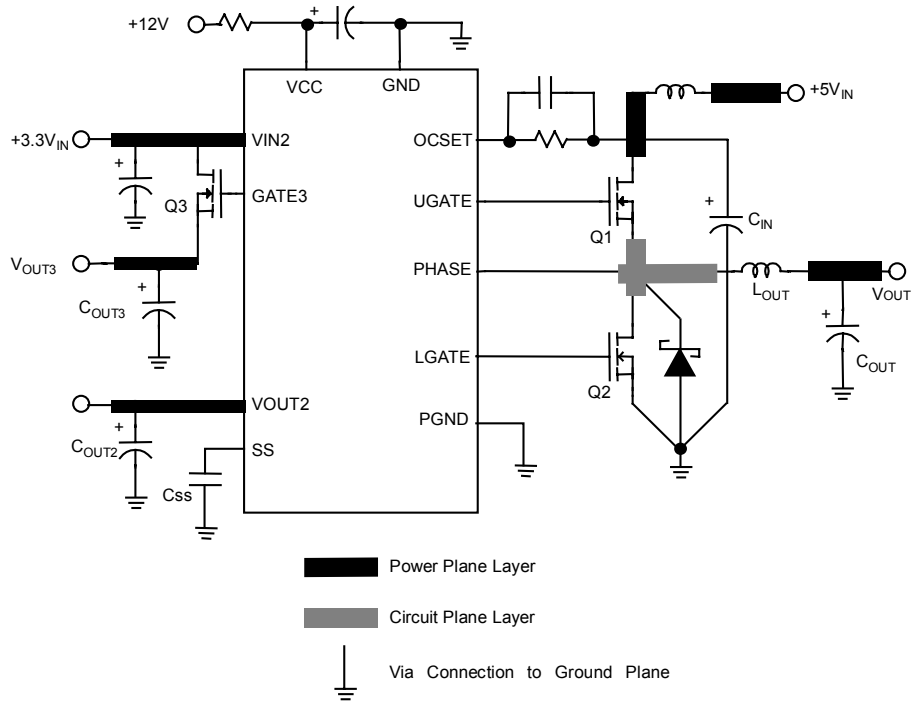

FIG 4. Printed circuit board power plane and islands

List of materials to AIC1570 application circuit diagram:

Reference	Part Number	QTY	PKG	Vendor	Second Source
U1	AIC1570CS	1 PCS	SO24	AIC	
Q1, Q2	CEP6030L	2 PCS	TO263	CET	
Q3	CET3055	1 PCS	SOT223	CET	
L1	1 μ H	1 PCS		H & D	CAILCRAFT
L2	3.5 μ H	1 PCS		H & D	CAILCRAFT
D1	1N5820	1 PCS		MOTOROLA	
R2	2.2KF	1 PCS	0805	Various	
R4	4.99KF	1 PCS	0805	Various	
R8	2.21KF	1 PCS	0805	Various	
R9	732KF	1 PCS	0805	Various	
R10	160KF	1 PCS	0805	Various	
R11	1.87KF	1 PCS	0805	Various	
R12,R13,R14	10KF	1 PCS	0805	Various	
R15	10RJ	1 PCS	0805	Various	
C 1~7, 24~36 C43~46, C19	1000 μ F	18PCS		SANYO	
C15,C16	1 μ F	2 PCS	0805	Various	
C18	1000pF	1 PCS	0805		
C40	0.68 μ F	1 PCS	0805	Various	
C41	10pF	1 PCS	0805	Various	
C42	2.2nF	1 PCS	0805	Various	
C47	270 μ F	1 PCS		Various	
C48	40nF	1 PCS	0805	Various	

Conclusion:

In a rapidly changing electronic industry, the challenge to R & D engineers is not only to design a quality product but also to meet low cost requirement. Based on these, Analog Integrations Cooperation introduces an integrated regulator

that includes PWM Controller, Linear Controller, and Linear Regulator. That is, it can provide three different output signals. Not only have a quality function and simple design, but also meets requirement for low cost.