

Optimized external driver for AIC1639

Stanley Chen

Introduction

AIC1639 is a member of AIC1638 PFM (Pulse Frequency Modulation) controller IC family, for step-up DC/DC converter featuring high efficiency and low ripple voltage, which is exactly the same as AIC1638 except the external driver with higher output current comparing to the built-in edition (AIC1638). The figures are shown below :

The key electrical characteristics of AIC1639

- ✓ PFM based control
- ✓ 75% (Typ.) oscillator duty cycle , 100KHz (Typ.) switching frequency
- ✓ Low start up voltage

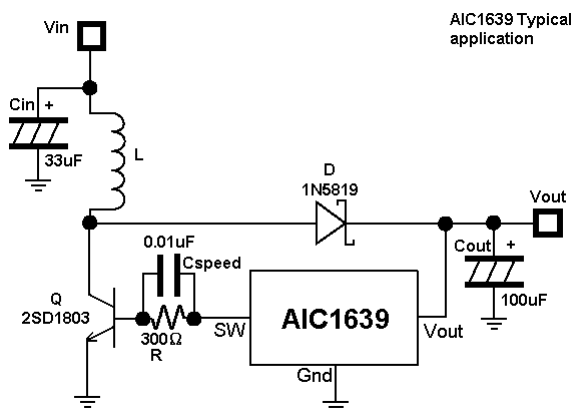

Figure 1a

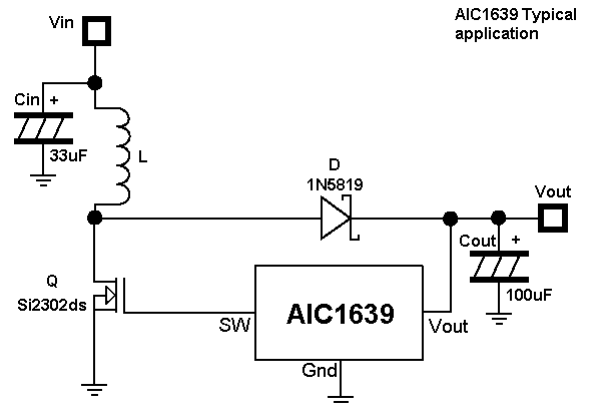
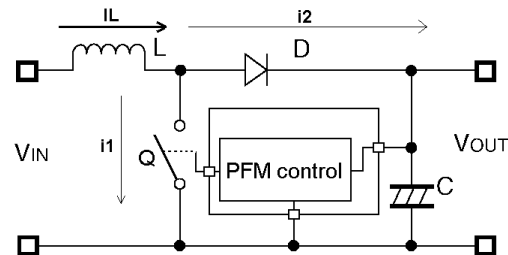

Figure 1b

Principle of step-up DC/DC converter operation

A step-up DC/DC converter charges energy in the inductor when the switch is on and discharges the energy with additional energy from Input Power Source thereto. Therefore a higher voltage output, than input, is obtained.

The operation will be explained with reference to the following diagrams :



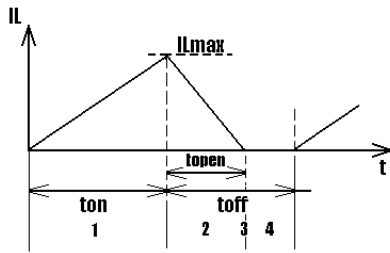

figure 2a<Basic circuits>figure 2b<Current through L>

Refer to figure 2a and 2b shown above

Step1: Switcher Q is turned on with the current flow of $I_L (=i_1)$ and the energy is charged in L. At this moment ($I_L=i_1$), I_L is increased from $I_{Lmin} (=0)$ to I_{Lmax} in proportion to the on-time period (t_{on}) of switcher Q which is given by :

$$I = \frac{V_{IN} \times t_{on}}{L} \quad (1)$$

That is , as the turn-on time gets longer , the current flow through inductor might get higher .

Step2: When Q is off, Schottky diode is turned on in order that L maintains I_L at I_{Lmax} . That causes the release of current $I_L (=i_2)$.

Step3: $I_L (=i_2)$ is gradually decreased. And I_L reaches to $I_{Lmin} (=0)$ in a period (t_{open}) so that the diode is off.

Switch transistor selection

NPN type bipolar transistor steady-state characteristics

Although there are three possible configurations, i.e.

CC , CE and CB. The CE (Common Emitter) configuration , which is shown in figure 3 for an NPN-transistor , is generally used in switching applications.

There are three operating regions of a transistor : cutoff , active , and saturation . In the cutoff region , either the transistor is off or the base current is not enough to turn it on . In the active region , the transistor acts as an amplifier, where the collector current is amplified by a gain and the collector-emitter voltage decreases with the base current . In the saturation region , the base current is sufficiently high so that the collect-emitter voltage is low. And the transistor is considered as a switch.

The transfer characteristics, a plot of V_{CE} against I_B , are shown in figure3 below .

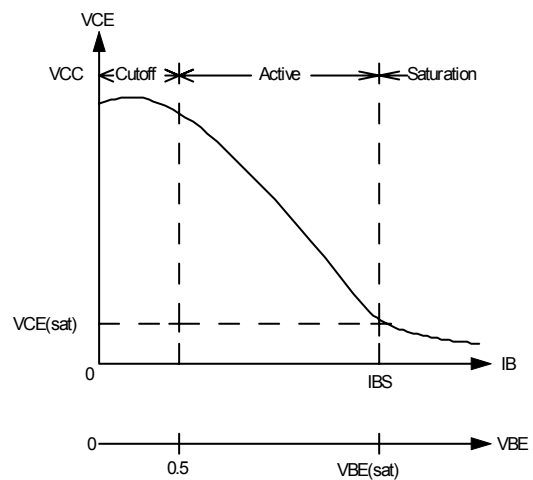

Figure 3

The model of an NPN-transistor is shown in Fig. 4 under large-signal dc operation, the relevant current is

$$I_E = I_C + I_B \quad (2)$$

The base current is the input current and the collector current the output current. The ratio of

collector current, I_C , to base current, I_B , is known as the current gain, h_{FE} :

$$h_{FE} = \frac{I_C}{I_B} \quad (3)$$

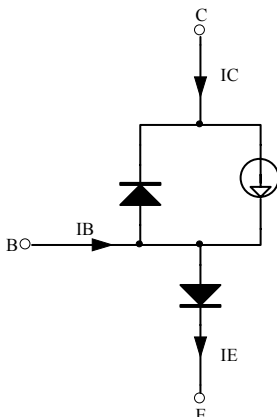

Figure 4 Model of NPN transistor

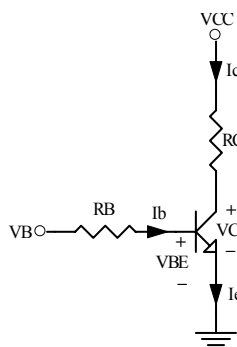

Figure 5 Transistor switch

Let us take a look at the circuit of Fig. 5, where the transistor is operated as a switch.

$$I_B = \frac{V_B - V_{BE}}{R_B} \quad (4)$$

$$V_{CB} = V_{CE} - V_{BE} \quad (5)$$

Equation (5) indicates that as long as $V_{CE} \geq V_{BE}$, the transistor will be in the active region. The maximum collector current (I_{CM}) in the active region, which can be obtained by setting $V_{CB} = 0$ and $V_{BE} = V_{CE}$, is

$$I_{CM} = \frac{V_{CC} - V_{CE}}{R_C} = \frac{V_{CC} - V_{BE}}{R_C} \quad (6)$$

and the corresponding value of the base current is

$$I_{BM} = \frac{I_{CM}}{h_{FE}} \quad (7)$$

If the base current exceeds I_{BM} , V_{BE} and the collector current increase and the V_{CE} falls below V_{BE} . This will continue until the CB junction is forward biased with V_{BC} of about 0.4 to 0.5V. The transistor then goes into saturation. The transistor saturation may be defined as the point above. Any increases in the base current do not increase the collector current significantly.

In the saturation, the collector current remains almost constant. If the collector-emitter saturation voltage is $V_{CE(sat)}$, the collector current is

$$I_{CS} = \frac{V_{CC} - V_{CE(sat)}}{R_C} \quad (8)$$

and the corresponding value of base current is

$$I_{BS} = \frac{I_{CS}}{h_{FE}} \quad (9)$$

The total power loss in the two junctions is

$$P_T = V_{BE}I_B + V_{CE}I_C \quad (10)$$

A high value of overdrive factor will not reduce the collector-emitter voltage significantly. However, V_{BE} will increase due to increased base current, resulting in increasing power loss in BE junction

Therefore, it is necessary that the setting of the input/output conditions and the selections of peripheral components are made with the consideration of I_{Lmax} .

Besides, there are also several key features to be considered, i.e.,

Collector to Emitter Saturation voltage $V_{CE(sat)}$

Collector current: I_C DC current gain h_{FE}

N type MOSFET transistor steady-state characteristics

The figure1b. shows the circuit example which is using N-MOSFET.

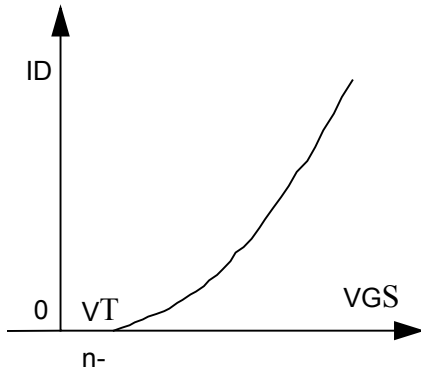

Figure 6 Transfer characteristic of N-Channel MOSFET

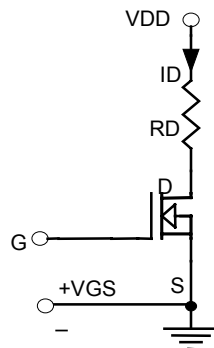

Figure 7 N-MOS transistor switch

Figure 6 shows the output characteristics of an N-channel MOSFET. There are three regions of operation: (1) cutoff region, where $V_{GS} \leq V_T$; (2) pinch-off or saturation region, where $V_{DS} \geq V_{GS} - V_T$; (3) linear region, where $V_{DS} \leq V_{GS} - V_T$, due to high drain current and low drain voltage, the power MOSFETs are operated in the linear region for switching actions.

The drain current I_D is given by:

$$I_D = k(V_{GS} - V_T)^2 \quad (11)$$

The V_T here is usually between 2V~4V, and k is usually 0.2 or 0.3. and the output resistance, R_{DS} , which is defined as :

$$R_{DS} = \frac{\Delta V_{DS}}{\Delta I_D} \quad (12)$$

is normally very high in the pinch-off region, typically on the order of megaohms ($M\Omega$) and is very small in the linear region, typically on the order of milliohms ($m\Omega$)

Since the ON resistor of the MOS FET might affect the output ability as well as the efficiency, the threshold voltage should be low. When the output voltage is as low as 2.7V, which is the same as AIC1639-27, the circuit operates only when the MOSFET has the threshold voltage lower than 2.7V

Fig 8. and Fig 9. show the difference between 4 transistors (3 NPN-type transistor and 1 N-type MOSFET) implemented for its load regulation and efficiency : ($V_{IN}=3.0V$, $V_{OUT}=5.0V$ $L=15\mu H$)

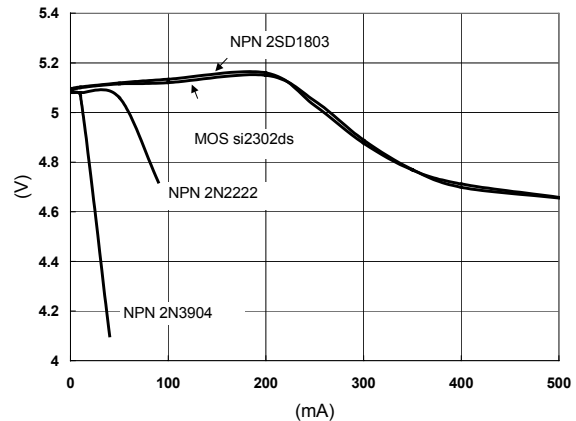
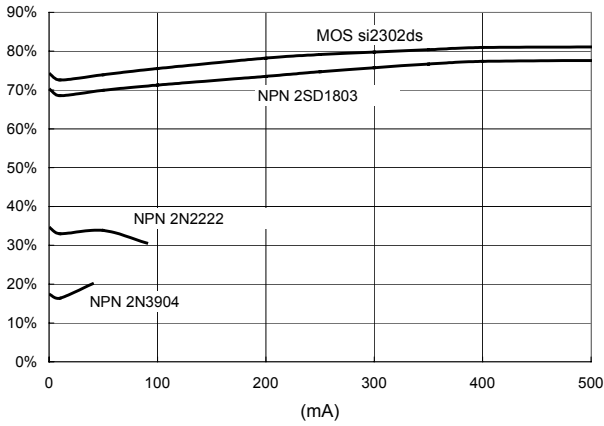

Fig 8. Efficiency vs Output Current



The figures tell us the general purpose of transistors (e.g. 2N2222, 2N3904...etc) are not recommended due to its low current capacity, low DC gain and high $V_{BE(SAT)}$ when larger switching current implemented.

Fig 9. Output Voltage vs Output Current

Characteristics list for transistors

| Transistor | I_{Cmax} | V_{BE} | V_{CE} | h_{FE} | remark |
|------------|------------|---|----------------------|----------------|---------------------|
| 2SD1803 | 5A | 0.75Vmax@ $I_C=0.15A$ 0.85Vmax@ $I_C=0.5A$ 1.35Vmax@ $I_C=3.0A$ | 0.07Vmax 0.22Vmax | 50min | High current switch |
| 2N2222A | 600mA | 1.30Vmax@ $I_C=0.15A$ 2.00Vmax@ $I_C=0.5A$ | 0.30Vmax 1.00Vmax | 50min 40min | General purpose |
| 2N3904 | 200mA | 0.95Vmax@ $I_C=50mA$ | 0.30Vmax | 60min | General purpose |

Fig 10. and Fig 11. also show the load regulation and efficiency for different type of transistor and inductance: ($V_{IN}=3.0V$, $V_{OUT}=5.0V$)

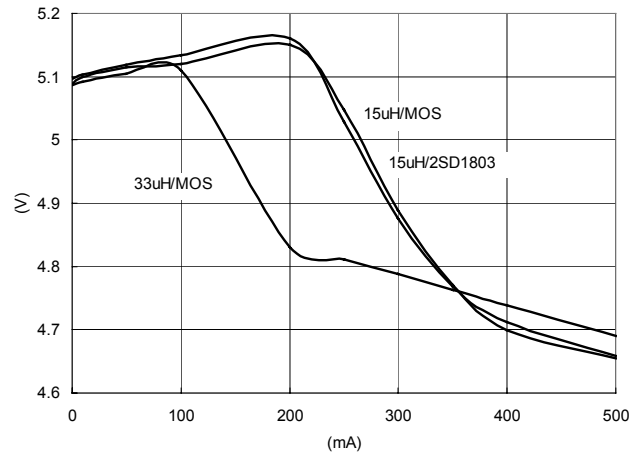
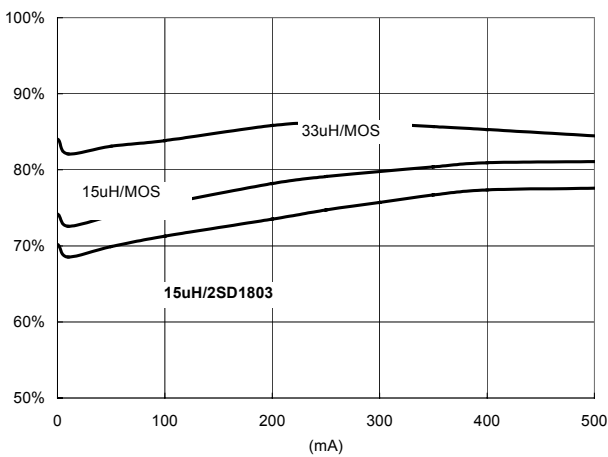

Fig 11. Output Voltage vs Output Current

Characteristics of N-type MOSFET Si2302DS

| Transistor | $I_{D_{max}}$ | $V_{GS(TH)}$ | R_{DS} | remark |
|------------|---------------|--------------|--|-------------------------------|
| Si2302DS | 10A | 0.65Vmin | 0.085 @ $V_{GS}=4.5V$ 0.115 @ $V_{GS}=2.5V$ | N-Channel 1.25-W 2.5-V MOSFET |

Layout

To insure good noise performance, use the following basic layout practices:

1. Minimize stray inductance by keeping board trace lengths to a minimum
2. Mount the controller IC as close to the load as possible to minimize output impedance.
3. Mount the supply decoupling capacitors as close as possible to the controller IC.

Recommended selection

As we can see, the MOSFET is a quite excellent choice to be the driver transistor of AIC1639 due to its low $R_{DS(on)}$ and outstanding performance in efficiency. However the threshold voltage should be

low . When the output voltage is as low as 2.7V, the circuit operates only when the MOSFET has the threshold voltage lower than 2.7V.

Besides, the transistor that is intended to used as high current switch featuring

- High collector current (I_C)
- Low saturation voltage for V_{BE} and V_{CE}
- High DC gain h_{FE}

Is recommended.

By estimating the switch current from output current to choose a proper peripheral component is the best way to enhance the voltage converter system and save more cost.

It would be great for your application! Come on, step it up!