

# The Power Management of PDA—The Application of SEPIC Circuit

Lauren Liu and Hanns Chiu

## Introduction

The PDA (Personal Digital Assistant) appeals to an increasing number of users because of its multifunction such as: Wireless Communication, Organizer, Mobile Phone, Handwriting Recognition, Web Access, Flash Memory, and Data/fax Modem. The users can choose their favorites among various brands according to their individual requirement. And the efficiency and the duration of the battery used in the products are critical to the users.

From the designers' point of view, the circuit for power management becomes obviously substantial. Here goes the block diagram of circuit in PDA.

Referred to Fig.1, it is easily seen that there are two possible combinations for input.

One way is to combine 2 Ni-MH cells and a 6V adapter. The combination causes the input voltage ranging from 1.8V to 2.6V. The other way is to put a Li-Ion battery and an adapter together. That results in a range from 2.4V to 4.3V for the input voltage. To have a regulated 3.3V input voltage for the controller, the voltage obtained from battery needs another treatment. The conventional method is to boost the battery voltage and then reduce it to what we expect. In this manner, regulated voltages are obtained from the battery steadily, regardless of the original level of the battery.

Nevertheless, there are some defects in the method

described above. For example, there would be an increase of the number of elements and space, higher cost, reduced reliability, and low efficiency of power transfer. This article introduces a better approach to achieve a regulated voltage. The benefits of the simplified circuit with low cost and high efficiency may result from this approach.

## Operation Principle

### A. The Description of the Circuit

Referred to Fig. 2, the SEPIC (Single End Primary Inductor Circuit) meets the requirement for the output voltage to tolerate any levels of voltage from input. You might have heard of "SEPIC", yet the corresponding operation theory, design guide, and application are not often employed in the literature. We provide insight of the circuit for your design.

As shown in Fig.2,  $L_1$  and  $L_2$  are chokes. They can be coupled or uncoupled.  $C_1$  and  $C_2$  are aluminum electrolytic capacitors.  $M_1$  is MOSFET and  $D_1$  is the power diode. When  $M_1$  turns on,  $D_1$  is off and  $V_{IN}$  and  $C_1$  provide energy to  $L_1$ ,  $L_2$ , respectively. In turn, as  $M_1$  turns off,  $D_1$  is on.  $L_1$  charges  $C_1$ .  $L_1$  and  $L_2$  provide electric energy to  $C_2$  and load from magnetic energy stored before. In steady state, the average voltage of  $L_1$  and  $L_2$  is zero and that of  $C_1$  is  $V_{IN}$ .

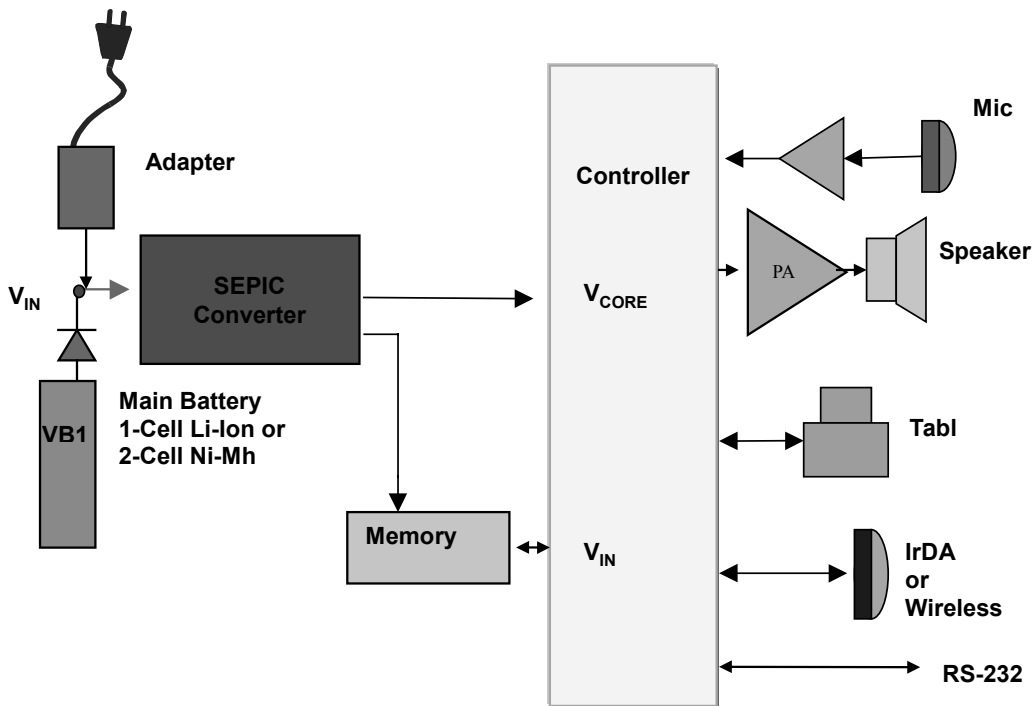

Fig.1 PDA power distribution Operation Principle

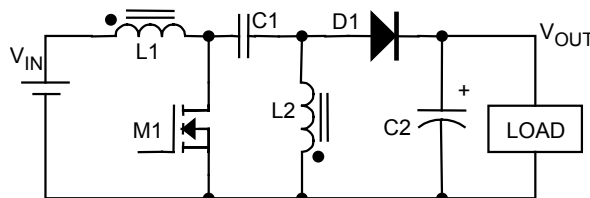

Fig.2 The topology of SEPIC circuit

**B. Analysis**

To have a small current ripple, the circuit has to be operated in the continuous conduction mode (CCM). Besides, there would be less electromagnetic interference in CCM. Therefore, the circuit is to be analyzed in this mode.

Mode. 1 ( $t_{ON} < t \leq T$ )

Refer to Fig.3, when M1 is on, the diode D1 is off and  $V_{IN}$  is across the inductor  $L_1$ . The current of  $L_1$  increases in linear proportion. Meanwhile, the voltage of  $C1$  is across  $L_2$  and, when  $L_1$  is the same as  $L_2$ , the current of  $I_{C1}$  and  $I_{L2}$  is identical. Until now,

the readers might be puzzled about equality of  $V_{C1}$  and  $V_{IN}$ . In steady state, the average voltage of inductor is zero, so  $V_{IN}$  is directly across capacitor  $C_1$ . That makes  $V_{C1}$  equal to  $V_{IN}$ . The plot of currents with respect to switching signal is shown in Fig.5 (a).

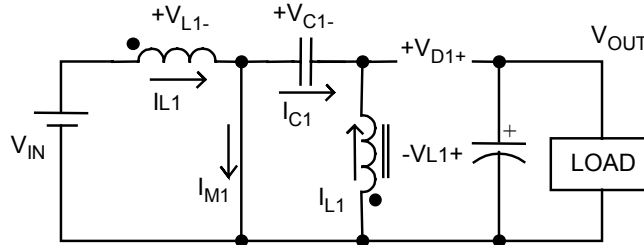

Fig.3 The equivalent circuit of Fig.2 when M1 is on and D1 is off

Mode. 2 ( $0 < t \leq t_{ON}$ )

As shown in Fig.4, when M1 turns off, the diode  $D_1$  is on and the magnetic energy stored in  $L_1$  is released to charge  $C_1$ . The current declines in linear proportion. The voltage across  $L_1$  is equal to minus  $V_{OUT}$ .

Similarly, the magnetic energy in  $L_2$  is transferred to

$C_2$  and the “load” as in fig. 3, which is a power plant. According to Kirchoff's current law,  $I_{D1}$  is the sum of  $I_{L1}$  and  $I_{L2}$ . If we neglect the forward drop voltage of diode  $D_1$ ,  $V_{L2}$  is equal to minus  $V_{OUT}$ . The plot of voltages with respect to switching signal is shown in Fig.5 (b).

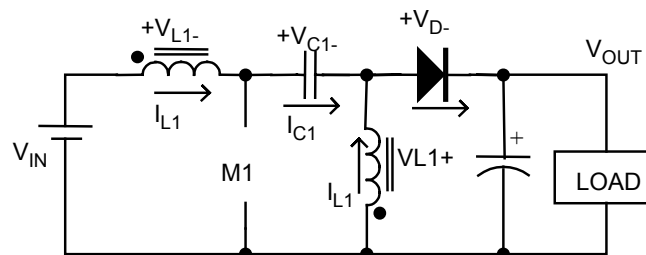

Fig.4 The equivalent circuit of Fig.2 when M1 is off and D1 on.

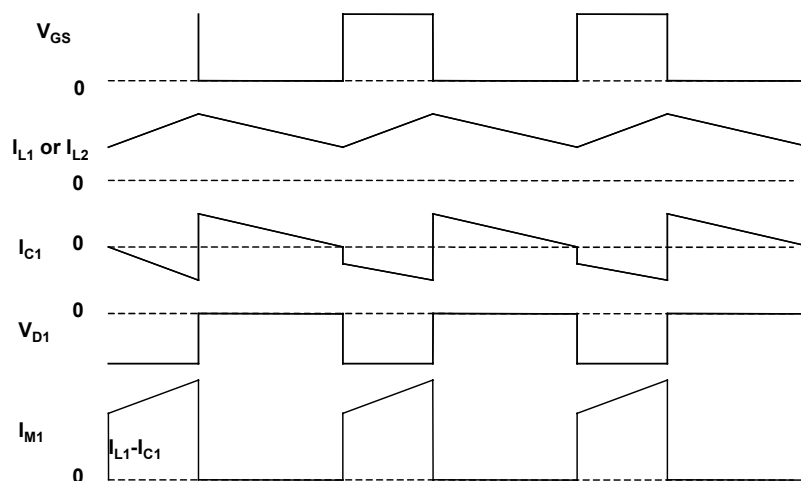

Fig.5 (a) The plots of currents

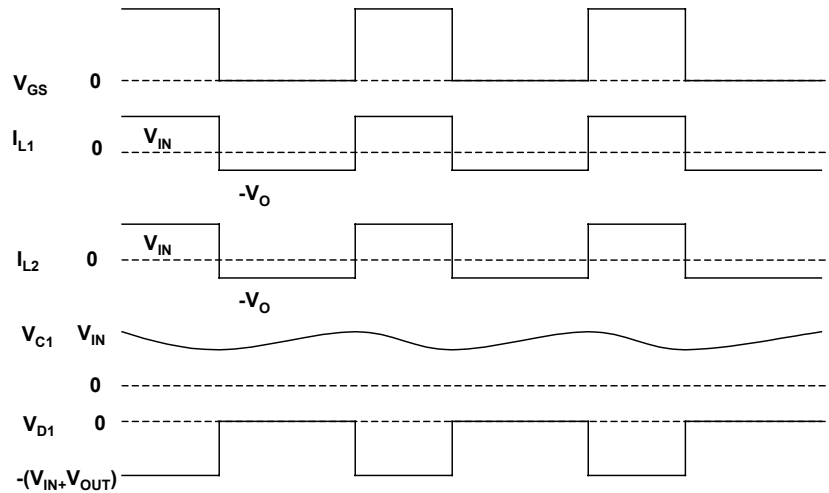

Fig.5 (b) The plots of voltages

In steady state, the characteristic of inductor is the voltage-second balance. Therefore, we can obtain the relationship between  $V_{IN}$  and  $V_{OUT}$  in (1). If we neglect the power loss in the converting circuit,  $P_{INPUT}$  equals  $P_{OUTPUT}$ . And the relationship of current between input and output is shown in (3), where  $D$  is the duty cycle.

$$V_{IN} \times D \times T_S = V_{OUT} \times (1-D) \times T_S \dots\dots\dots (1)$$

$$\frac{V_{OUT}}{V_{IN}} = \frac{D}{1-D} \dots\dots\dots (2)$$

$$\frac{I_{IN}}{I_{OUT}} = \frac{D}{1-D} \dots\dots\dots (3)$$

**Design Guide**

From the description above, here is a typical design example.

In MP3 or PDA, the battery is the power source to the DC/DC converter. The voltage fluctuates due to the change of battery capacity. To obtain regulated voltage from battery source regardless the level of the voltage, the SEPIC circuit is preferred.

There are some specifications in this design example:

The range of input voltage: 2.9V~4.5V

The desired output voltage: 3.3V

The maximum current:  $I_{OUT}=500mA$

Step 1: Selection of  $L_1$  and  $L_2$ .

AIC1630A, one of products for power management from AIC, is the switching controller whose switching frequency is from 90kHz to 150kHz.

$$T_S = 1/F_{S,MIN} = 1/90k = 11.1 \mu S,$$

$$\left( \frac{V_{OUT}}{V_{IN}} \right)_{MIN} = \frac{D_{MAX}}{1-D_{MAX}},$$

$$\frac{3.3}{2.9} = \frac{D_{MAX}}{1-D_{MAX}},$$

$D_{MAX}=0.53$ .....the maximum duty ratio

$$I_{OUT-BOUNDARY} = I_{OUT-MAX} = 0.5A,$$

$$L_1 > \frac{V_{OUT} \times T_S \times (1-D)}{2 \times I_{OUT-BOUNDARY}}$$

$$L_1 > 17.2 \mu H$$

Let  $L_1$  be 25 $\mu H$ .

$$I_{IN} = \frac{P_{IN}}{V_{IN}} = \frac{P_{OUT}}{EFF. \times V_{IN}} = \frac{3.3 \times 0.5}{0.8 \times 2.9} = 0.71A$$

Step 2: Selection of  $C_1$

$$C1 = \frac{D \times T_S \times I_{IN}}{D_{VC1}}$$

$$C1 = \frac{0.53 \times 11.1 \times 0.71}{3.3 \times 0.05} = 25.3 \mu F$$

Let  $C_1$  be 47 $\mu$ F/10V/Low ESR

Step 3: Selection of  $M_1$  and  $D_1$

$M_1$ : voltage stress >  $V_{IN} + V_{OUT} = 4.5 + 3.3 = 7.8V$ ,

Current stress >

$$\text{Current stress} > I_{IN} \times \frac{2}{D_{MAX}} \times \frac{1}{1+K}$$

$$= 0.71 \times \frac{2}{0.53} \times \frac{1}{1+0.5} = 1.78A$$

Where  $k = \frac{I_{P1}}{I_{P2}}$ ,  $1 > k > 0$

Let it approximate 0.5.

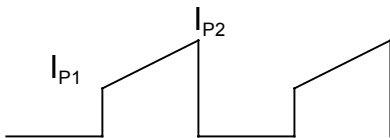

Fig.6 The current of  $M_1$

$M_1$  is chosen to be CEM4410 (30V/10A)

$D_1$ : voltage stress >  $V_{IN} + V_{OUT} = 4.5 + 3.3 = 7.8V$ ,

Current stress equals to  $M_1$

$D_1$  is SB220 (20V/2A)

The whole circuit is shown below.

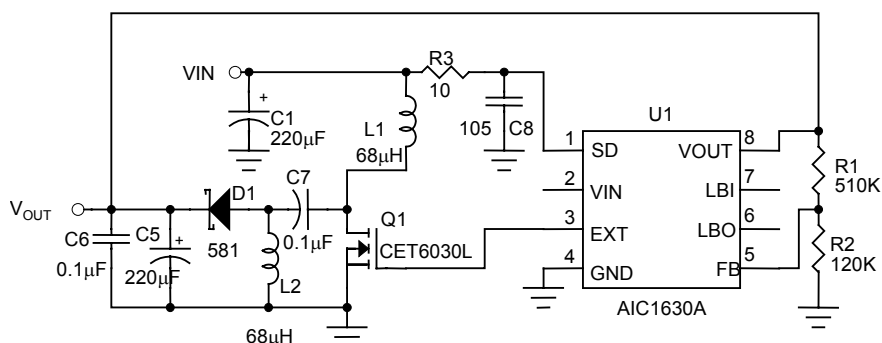

Fig.7 The SEPIC circuit of AIC1630A

### Experiment Results

The results of experiment are shown below.

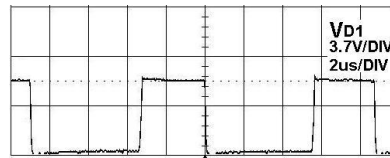
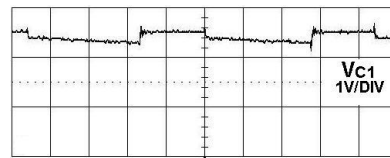
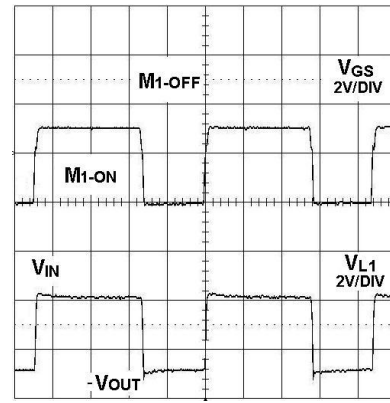
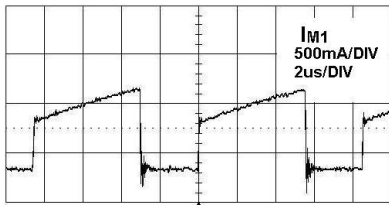
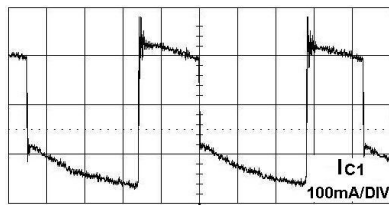
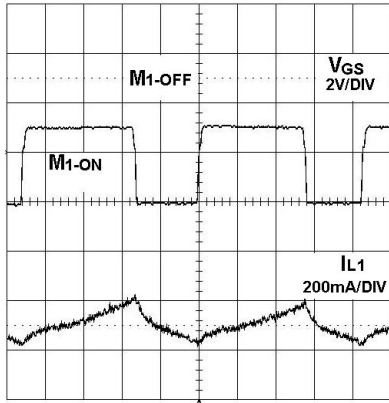

Fig.8 (a) The plot of currents with respect to switching signal

Fig.8 (b) The plot of voltages with respect to switching signal.

**Summary**

Based on the calculation and description above, the SEPIC can be accurately designed. It is recommended especially in the applications where the battery is the power source in the appliances or the regulated voltage is demanded from the power source regardless the level of the voltage.

Although the efficiency of SEPIC circuit is lower than BUCK converter or BOOST converter, it beats the conventional method, that is, boosting the source voltage first and reducing it afterwards. For the low power-consumption portable appliances, SEPIC is a good option with benefits of simple circuit and low ripple current.

We sincerely hope that this circuit could be of some help to engineers in related field. Other topics, e.g. the power management of portable appliances, the circuit combined to the charger, the boost mode circuit and some problems encountered in the design process, will be presented in the near future.

**Reference:**

[1]. AIC1630A Datasheet, Analog Integrations Corporation 2000.