

Two-Cell, Step-Up Converter Design for Portable Applications

James Liu

Introduction

In recent years, the markets for portable electrical devices, such as the electronic dictionary, palmtop computers, notebook PCs, PDAs and cellular phones has grown rapidly. All of these devices use batteries as the source of power. Due to their limitations of small size and light weight and due to increasingly stringent environmental requirements in product development, the use of small numbers, small size, long-lasting batteries has become a trend.

The AIC1630/1631/1633 are very suitable for the application of using 2~4 batteries. This article will focus on the application of AIC1631-5 for 2 batteries in the following description.

A set of two alkaline, NiMH, or NiCd battery cells accompanied by a switching converter with 3V, 3.3V, or 5V output voltage is frequently used as the power supply source for portable electronic products. Using two battery cells is usually a result of compromise between size and battery operating life. Besides the batteries' own stored energy, two other factors also influence batteries' operating life: the product's power consumption and conversion efficiency of the converter. In order to choose the appropriate switching converter for an electronic product, therefore, 5 key factors need to be considered:

- (1) The current capacity and regulation of the output should meet the product's demands.
- (2) High conversion efficiency.
- (3) Low power consumption.

- (4) Squeeze out as much of the battery energy as possible.
- (5) Small size and light weight.

The first factor is absolutely necessary, and the importance of the other four differs in priority depending on the character of the product. For products, which operate relatively high current for extended time periods, conversion efficiency is paramount. For products operate with low current for most of the time, the current consumption of the converter itself must also be low. With regards to size and weight, an 8-pin IC, which does not need a heatsink, with a small inductor, and minimum number of external parts, would be an ideal choice. In the following, we use the AIC1631 DC/DC converter as an example for several different special products using two battery cells to demonstrate how the AIC1631 can be used to make an ideal power source.

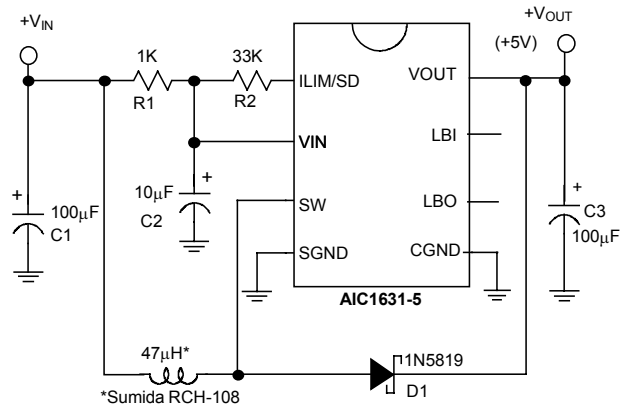

Fig. 1 A High-Efficiency 2-Cell to 5V Converter

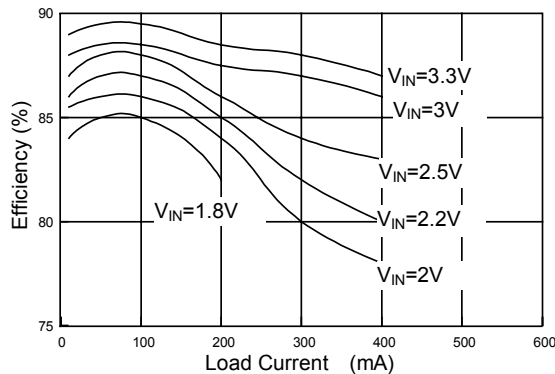

Fig. 2 Conversion Efficiency for the 5V Converter

Conversion Efficiency Considerations

Conversion efficiency is the main consideration for those devices which consume above 2mA most of the time. Fig. 1 shows a high efficiency converter circuit suitable for producing 5V output from two battery cells. The components shown in Fig. 1 are easily obtained low cost common parts. If high-quality parts (such as MMP core inductors) are used, efficiencies of 90% and above can be reached. However, if good output power quality is desired, such as in Fig. 2 or better, at least two points need to be observed:

- (1) A good power plan and a correct layout for the circuit board is a must. The AIC1631 evaluation boards are available for your reference.
- (2) One must have the correct inductor values. The equivalent series resistance of the inductor must be low and the core must not be saturated under any operation condition. The above example uses the Sumida RCH-108 47 μ H inductor, whose coil resistance (R_{DC}) is 0.14 Ω .

When converting 2 alkaline battery cells to 5V, an inductor of 40-150 μ H is suggested. For NiCd batteries, a 20-100 μ H inductor is suggested.

Inductors of less inductance can output a larger current. However, too low inductance would result in serious efficiency loss due to inductor core saturation. The most reliable method, therefore, is to test for the best conditions using a range of suggested values. The lower coil resistance (R_{DC}) be chosen, the better efficiency obtained. For products consuming about 20mA, the R_{DC} should be under 1 Ω . For products with current consumption at or above 50mA, the R_{DC} should be below 0.5 Ω . The larger the consumption current, the smaller the R_{DC} required.

Low Power Consumption Products

The quiescent current of the AIC1631-5 in a no load state is about 200 μ A. For special energy-conscious products, some circuit configurations are presented here to illustrate how the AIC1631 can be used:

- (1) If this DC/DC converter is not required to maintain output voltage, you may simply pull pin 1 (shutdown pin) to ground by using a control signal. The AIC1631 will stop functioning and the power consumption drop to less than 10 μ A. Normal operation can be recovered by pulling pin 1 high. Generally speaking, this is ideal for systems with backup lithium batteries. Fig. 3 is an example circuit. While using the lowest possible amount of power, the circuit makes it possible to retain data in memory even when changing batteries.

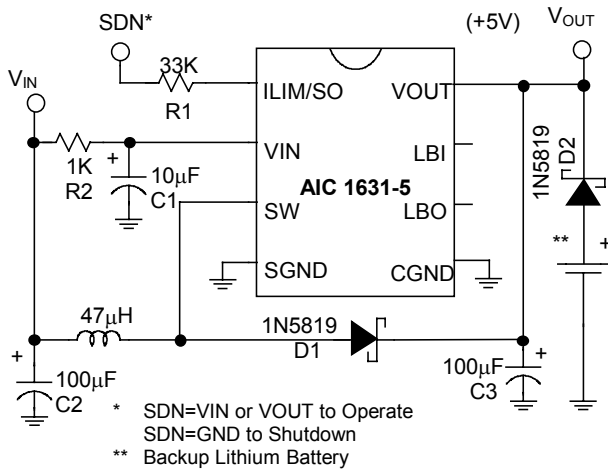
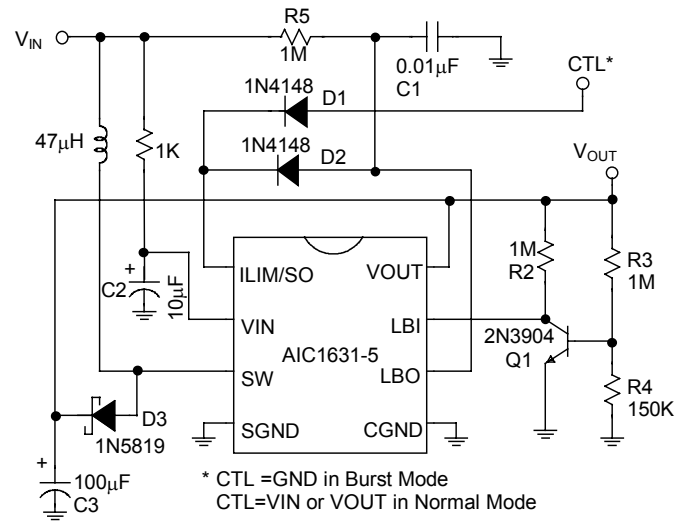
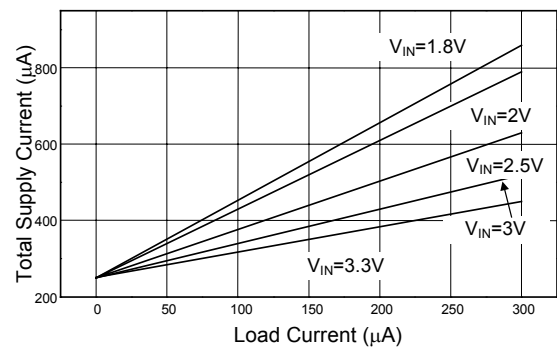

Fig. 3 Step-Up converter with Shutdown Control



(a)

(2) If the output voltage requires the AIC1631, one could add a few external components to make an oscillator to generate control signals for the AIC1631 to perform intermittent operations. This is called “Burst Mode Operation”, and is shown in Fig. 4(a). If CTL shown in Fig. 4(a) is connected to V_{IN} or V_{OUT} , the circuit will function normally with the characteristics similar to the circuit in Fig.1. If CTL is connected to GND, the circuit will enter Burst Mode with an output voltage of 4V, and the circuit itself consumes very low power, as shown in Fig. 4(b). To change the output voltage in the burst mode, simply change the divider ratio of R_3 and R_4 in Fig. 4(a). Note that the voltage of normal operation will never be exceeded.



(b)

Fig. 4. Low Supply Current, Burst Mode Step-Up Converter

(a) Application Circuit

(b) Total supply Current vs. Load Current

(3) To get the most out of the batteries' energy, the DC/DC converter must be able to work at low battery voltage. The circuit shown in Fig. 5 still deliver 30mA at 5V with input voltage at 1.6V. The conversion efficiency, however, is somewhat lower than circuit in Fig. 1.

These examples shown above use the AIC1631-5 to produce a 5V output. The AIC1631 and AIC1631-3 can be used similarly to produce 3.3V and 3V, respectively.

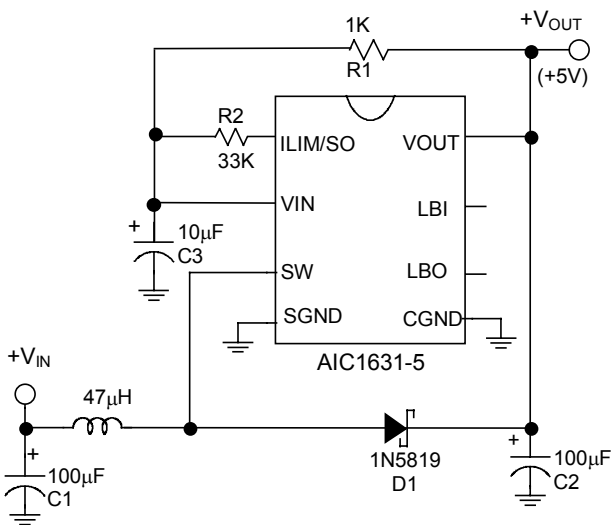
Fig. 5 1 Cell to 5V Step-Up Converter

Alkaline cells to 5 volts. The low dropout linear regulator is composed of the low battery detector (LBI and LBO pins), resistors R1, R2, R3, R4, and a PNP transistor 2SA1244, while the other components perform the job of a step-up switching regulator. The 1N4148 raises the output voltage of the switch regulator by 0.4V, allowing the linear low dropout regulator to filter out ripple noise. This results in a 7% loss in conversion efficiency, a necessary price to pay for a clean power source. The lower the output voltage, the higher the conversion efficiency loss due to this 0.4V voltage drop. For 3.3V (the AIC1631) and 3V (the AIC1631-3) output voltages, it creates a conversion efficiency loss around 10%.

2~4 Cells to 5V Low Noise Power Supply

The AIC1631-5 can be used to convert 2-4

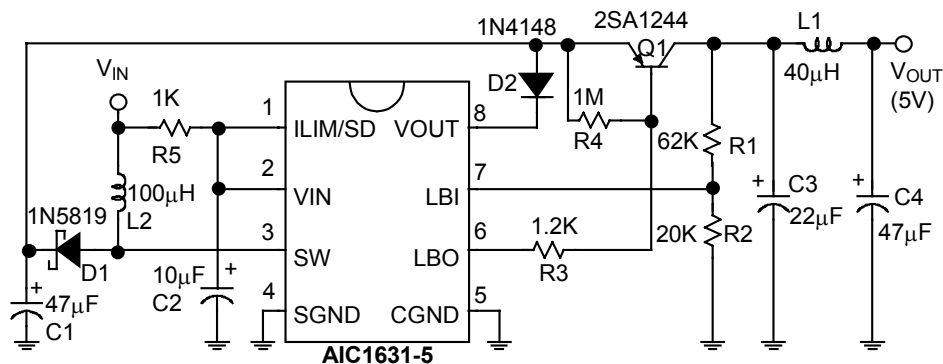
Fig. 6 2~4 Cells to 5V Low Noise Power Supply

Components Selection

A few guidelines can be followed when using the LBI and LBO pins of the AIC1631 (also the AIC1633 and the AIC1630) to form a low dropout linear regulator. One can see from Fig. 6, that output voltage is:

$$V_{OUT} = \frac{(R1 + R2)}{R2} \times 1.22V$$

The usable range of values for R4 is very large. Ordinarily, 1MΩ is a good choice, R3 must match with the PNP transistor. Since the current gain of the PNP transistor is usually only between 5 and 30 when $V_{CE}=0.4V$, the output current capability will be inadequate if the R3 value is too large. On the other hand, since the LB loop can adjust automatically, it will be acceptable if R3 value is a little smaller. However, if we use the right value for R3, in addition to its normal function, it can also

perform current limiting function. Normally, when output current is below 300mA and the PNP transistor is selected according to the following guidelines, the R3 value would be between 1K Ω and 5K Ω .

The first rule in selecting a PNP transistor is that the rated current should be high enough. Secondly, current gain β of the PNP must be maintained at greater than 10 (the greater the value the better) when $V_{CE}=0.4V$ and I_C is equal to or larger than the required output current. The transistor 2SA1244 in Fig. 6 is a good example.

Since under some circumstance, the use of a capacitor with too large capacitance value or too low ESR value (such as OSCON capacitors) can easily shift the dominant pole of the linear regulator and causes an oscillation situation. An electrolytic or a tantalum capacitor with capacitance lower than 100 μF is suggested for the capacitor C3.

Due to the limited bandwidth of the linear regulator and the ESR effect of C3, high frequency spikes and noises may pass the linear regulator and appear at the output terminal. L1 and C4 are therefore added at the output node to form a π filter to filter out high frequency noises and obtain a truly clean power source.

PCB Layout Hints

With a correct PCB layout, the output voltage noise of the circuit, shown in Fig. 1 should be below 20mV (Peak to Peak). Under most circumstances, the noise cannot even be seen. However, sometimes one can see ringing of about

10MHz on the oscilloscope. This is referred to as ground noise. Ground noise is conducted by the PCB ground traces and closely related to the layout of the ground plane. How do we distinguish ground noise? Simply connect the ground end of the oscilloscope probe to different spots of the ground plane. If the noise's magnitude or shape changes significantly, then it is ground noise. In practical applications, we only need to apply a 0.1 μF ceramic capacitor across the power input terminals of the analog circuit, as shown in Fig. 7.

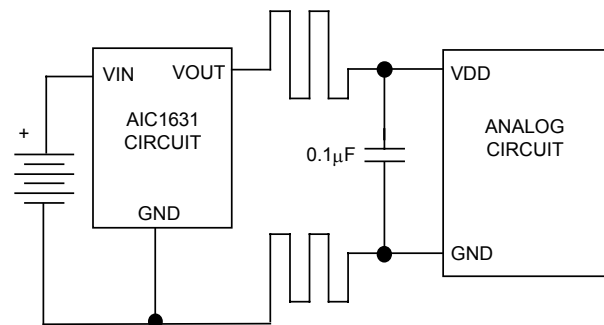

Fig. 7 Ground Noise Reduction by Using a 0.1 μF Ceramic Capacitor