

High Efficiency LCD Bias Design by Using AIC1650

Ben Tai

In general, black-and-white LCD display requires a negative high voltage power source for gray-scale contrast bias control. If this power is converted from the 5V or 3.3V main power, often supplied from the battery cells, a secondary conversion loss results. This article introduces a design which provides a stable negative voltage power source directly from the battery with high power conversion efficiency.

LCD applications are becoming more and more popular, especially for battery operated systems, such like notebook computers, electronic dictionaries, mobile phones, etc.. In some cases, black-and-white LCDs require a negative high voltage power source for gray-scale contrast bias control.

Fig. 1 shows the basic topology of a Buck-Boost DC/DC converter (switching regulator). The polarity

of output voltage is negative and magnitude can be less than, equal to or greater than the input voltage. The basic operation principle is using output voltage feedback to control the ON-and-OFF state of the power switch to obtain the specified output voltage level. For low power applications, conventional PWM control schemes are not ideal, because first, the low conversion efficiency due to high switching losses as compared to low output power, and second, the fact that the PWM controller requires a minimum load to maintain its stability. The most efficient and reliable control method is then to use a Pulse-Skipping-Modulation switching control, which the control waveforms are shown in Fig. 2. This switching control method can put the DC/DC converter into quasi-sleeping mode under no load or light load condition, which reduces switching losses while maintaining high conversion efficiency and good stability.

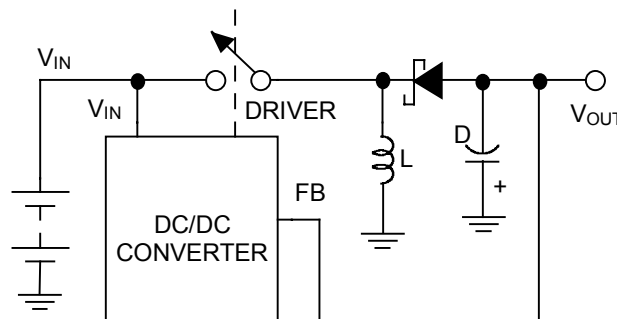

Fig. 1 The Basic Structure of the Inverting DC/DC Converter

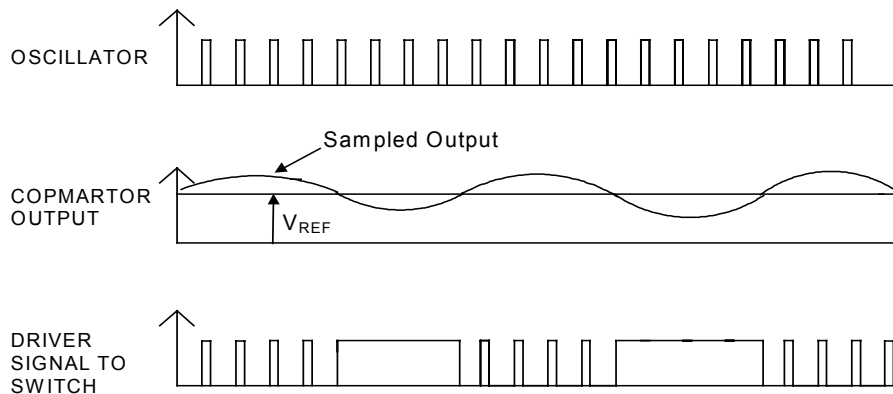

Fig. 2 Pulse-Skipping Operation Waveforms

One of the biggest challenges in designing a DC/DC converter is the selection of the proper inductance value, if the inductance is too large, the output power will be insufficient, yet if inductance is too small, the switching losses become too high. When a Pulse Skipping control is used, the inductance should be inversely proportional to output power. It is also closely related to input voltage and the T_{ON}/T_{OFF} duty cycle ratio of the oscillator. If the duty cycle does not change with input voltage variations, like PFM designs such as the AIC1650, the inductance value can be expressed by the following simple formula: (Equation 1)

$$L \leq (11.1 - 0.15 \times V_{IN}) \times \frac{V_{IN}}{|V_{OUT}| \times |I_{OUT}|} \dots\dots\dots(1)$$

Fig. 3 shows graphic curves of Equation 1. The result calculated from Equation 1 give the optimum value for the most stable operation and the highest conversion efficiency.

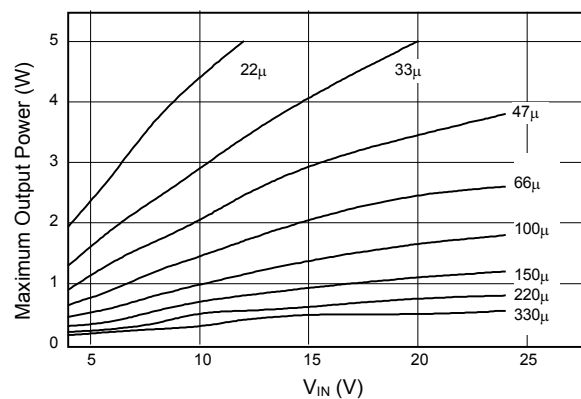

Fig. 3 Optimal Inductance Chart

Fig. 4 is a positive-to-negative inverting DC/DC converter designed with the AIC1650. This converter has the following advantages:

- (1) The input voltage is in the range of 4V~24V.
- (2) The externally adjustable output voltage magnitude can be over -40V.
- (3) The IC itself consumes a few power (100µA).
- (4) It works with high switching frequency (100KHz to 320 KHz), allowing designer using of a small inductor.
- (5) Build in shutdown function mode.
- (6) With a dual-output push-pull driver, good efficiency is possible with driving the

PNP.transistor.

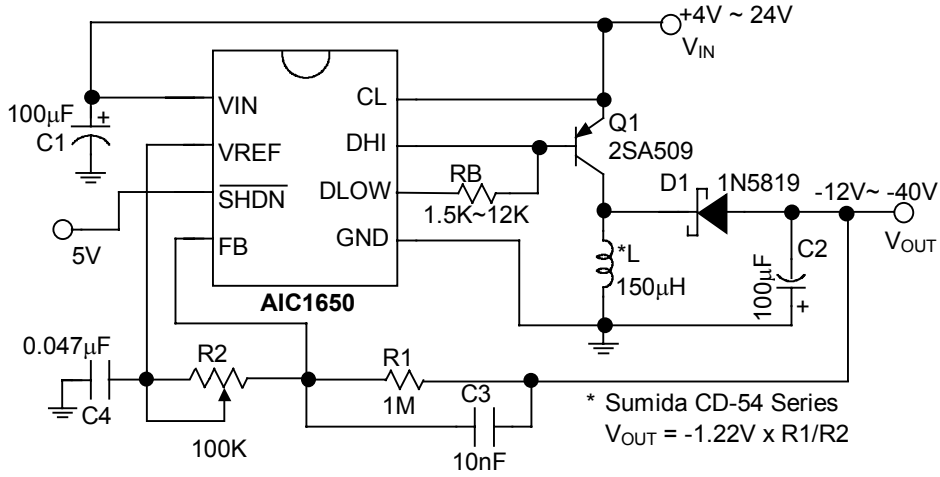

Fig. 4 Negative LCD Contrast Bias Power Supply.

Fig. 5 and Fig.6 are efficiency plots obtained under output requirements of $V_{OUT} = -22V$ and $I_{OUT} = -10mA$, with different input voltages and inductance values. As you see, the efficiency can reach over 85% when $|I_{OUT}| > 5mA$. In addition, as long as the output power is sufficiently large, better efficiency is achieved by using larger inductor values.

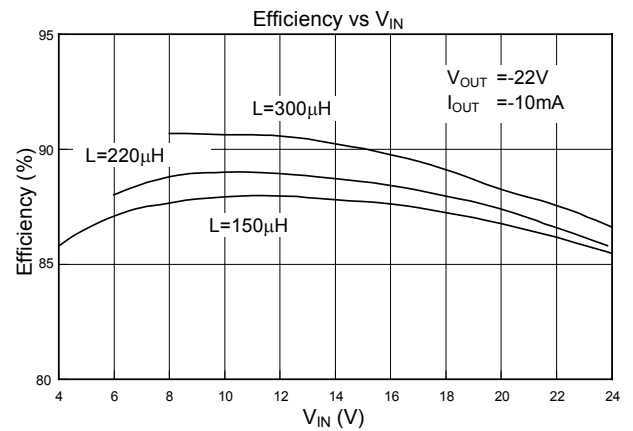

Fig. 6 Conversion Efficiency Chart

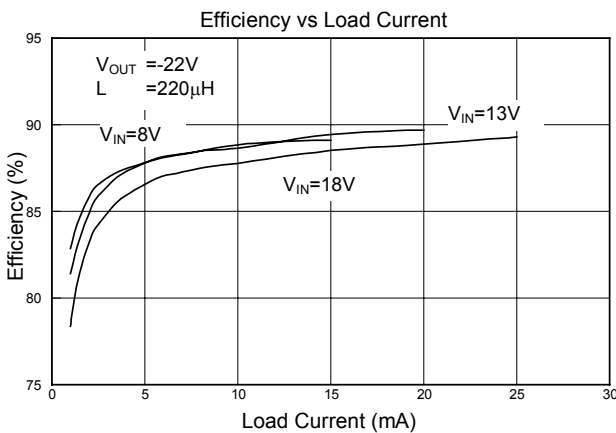

Fig. 5 Conversion Efficiency Chart