

Universal Step-Down DC/DC Converter Design Using AIC1563

Ben Tai

Abstract

Voltage required in the modern electronic systems are single or multiple regulated voltages such as 3.3 V, 5V, 12V, -5V, or -12V, etc. It can be supplied by using DC/DC converters. The operations of Step-Down DC/DC converter is introduced in the application note. A practical constant voltage, DC/DC step-down converter design based on the AIC1563 is also illustrated to help the readers in the circuit designs and applications.

Operations of Step-Down DC/DC Converter

Figure 1 shows a basic circuit configuration of step-down DC/DC Converter.

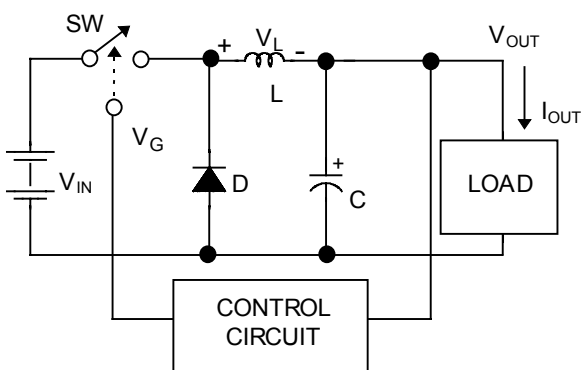

Fig. 1 Step-Down DC/DC Converter

The voltage and current waveforms in the circuit are shown in Fig. 2. The control circuit is used to detect the output voltage level and generates a

driving signal to turn on or turn off on the power switch (SW). The power switch can be controlled by using different methods, such as pulse width modulation (PWM), pulse frequency modulation (PFM), or pulse skipping modulation (PSM), depends on the applications. As for the output voltage stability, it is maintained by controlling the duty cycle without losing energy. This may be illustrated by examining the energy stored in the inductor.

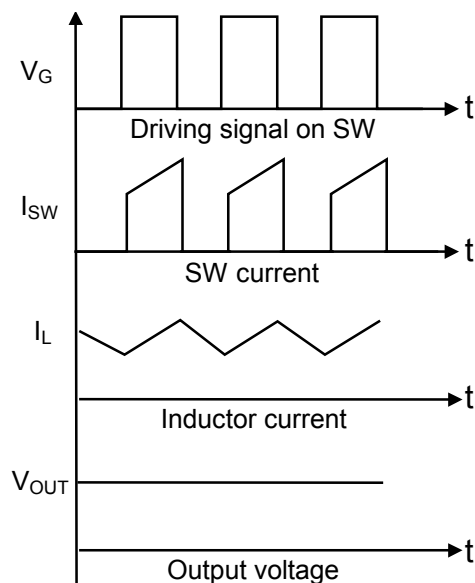

Fig. 2 Voltage and current waveforms of converter

The input electric energy is delivered to the load and partially stored in an inductor during the power switch turned on. The stored energy will be also transferred to the load through a free-wheel diode

during the power switch turned off. Figure 3 shows

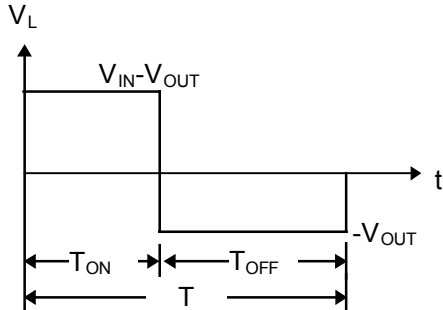

Fig.3 Voltage waveform of the inductor

Here PWM control method is used to illustrate the relationship between input and output voltage. It can also be applied to both PFM and PSM. To prevent the inductor from saturation, the inductor must release the same amount of energy as is stored under the stable condition. If not so, the inductor will enter a saturation region and lose its capability of storing energy due to unbalanced energy. This can be expressed as

$$\frac{1}{T} \int_0^T V_L \times I_{OUT} \times dt = 0 \dots\dots\dots(1)$$

In which T is the period, V_L is the inductor voltage, and I_{OUT} is the output current (DC). From Fig.3 we can derive

$$(V_{IN} - V_{OUT}) \times T_{ON} = V_{OUT} \times T_{OFF} \dots\dots\dots(2)$$

$$\frac{V_{OUT}}{V_{IN}} = \frac{T_{ON}}{T_{ON} + T_{OFF}} = \frac{T_{ON}}{T} = DUTY \dots\dots\dots(3)$$

Where DUTY is the duty cycle ratio. Eq. 3 indicates that the ratio of output voltage to the input voltage is the duty cycle ratio. Therefore, by sensing the output voltage to control the duty cycle, the output voltage can be well stabilized.

In the following two sections, the operations and a practical design example of AIC1563 are explained

the voltage waveform of the inductor in a cycle. in detail.

Operations of AIC1563

Basically AIC1563 is a universal DC/DC converter IC that may be applied to the design of step-down DC/DC converter, step-up DC/DC converter, and inverting DC/DC converter. It has an ultimate performance when it is applied to a step-down DC/DC converter. Figure 4 is a function block diagram of AIC1563 that consists of a frequency generator, a voltage comparator, a current limiting controller, a Darlington switching transistor, and bootstrap driver.

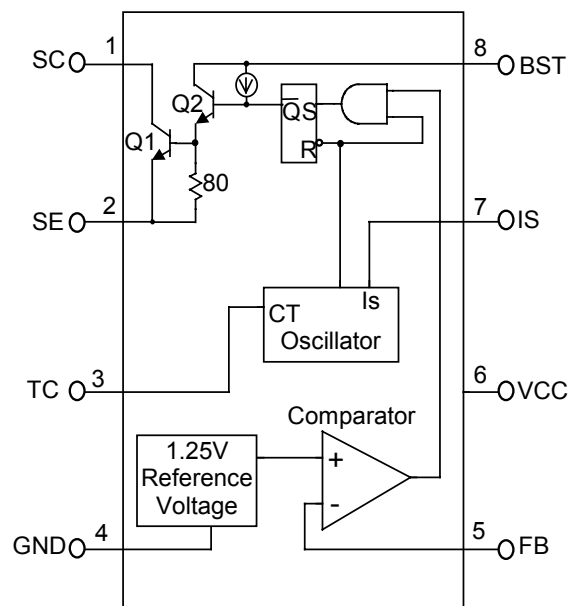

Fig. 4 AIC1563 function block diagram

The working voltage of AIC1563 is between 3V and 30V. It is recommended to operate it between 50KHz and 100KHz to obtain an optimum performance, although its operating frequency is ranging from 10 Hz to 100 kHz. AIC1563 is controlled by pulse skipping modulation (PSM). When the output voltage at FB pin of voltage

comparator is below 1.25V, it drives the Darlington switching transistor with a constant frequency and duty cycle to elevate the output voltage. On the other hand, the Darlington switching transistor stops switching when the output voltage at the FB pin is higher than 1.25V, and the output voltage will be decreased to stabilize the output voltage. Figure 5 is the time sequence waveforms for the

pulse skipping modulation control method. As it is shown, this type of control can attain the stable state naturally without a compensation circuit. In addition, this control method requires a simpler circuit with low quiescent current and it can achieve very high voltage conversion efficiency under light load.

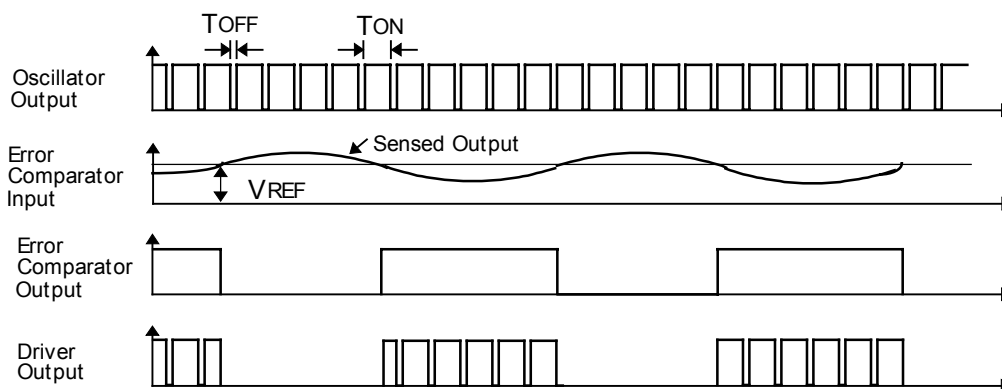

Fig. 5 Time sequence waveforms of pulse skipping modulation (PSM)

In a switching type DC/DC converter, the switching loss of the switch can affect the converter's efficiency directly. Since a high side switch is configured in a step-down DC/DC converter, a PNP transistor is normally used. However, the characteristics, cost and suppliers of PNP transistors are not as good as that of NPN transistors. The problem with using NPN transistors is that they cannot be driven to the saturation region if they are switched on high side. This leads to a lower converting efficiency. AIC1563 not only uses a 2A peak current NPN transistor as a switching switch, but also includes a bootstrap driver to drive the transistor into the saturation region. This has improved the efficiency dramatically. Running it in a continuous output current below 1.5A is the best working condition. Its efficiency can be as high as 90% depending on the external components used. There is no need to

add extra heat sink fins to an 8-pin DIP package with a 1.5A output current. If larger output current is required, an inexpensive NPN transistor can be added externally. The bootstrap driving circuit can also drives the external NPN transistor into the saturation region ($V_{CE}=0.4\text{ V}$) to achieve a high efficiency.

Constant Voltage DC/DC Converter Design

The main voltage source required for the electronic system products such as video CD, DVD, modem, and scanner is either 5 V or 12 V, with a maximum current of 1 A. We take this as an example to design a 5V/1A constant voltage DC/DC converter.

Table 1 is the electrical specification for the design

example. We select the operating frequency of 50 KHz

Table 1 Specifications for constant voltage DC/DC converter application example

Items	Symbol	MIN.	TYP.	MAX.	UNIT
Input voltage	V _{IN}	8		15	V
Output voltage	V _{OUT}	4.75	5	5.25	V
Output current	I _{OUT}	0.1		1	A
Output ripple voltage	V _{RIPPLE}		50		mV

The Figure 6 is an application circuit diagram of DC/DC converter. The voltage divider resistors RA and RB for output voltage feedback can be obtained from the formula

$$V_{OUT} = 1.25 \times \left(1 + \frac{R_B}{R_A}\right) \dots\dots(4)$$

Since we have assumed the output voltage to be 5 V, the ratio of RB/RA is 3. The sum of RA and RB is best selected between 10 KΩ and 50 KΩ. Therefore, we choose RA to be 10 KΩ, and RB to be 30 KΩ.

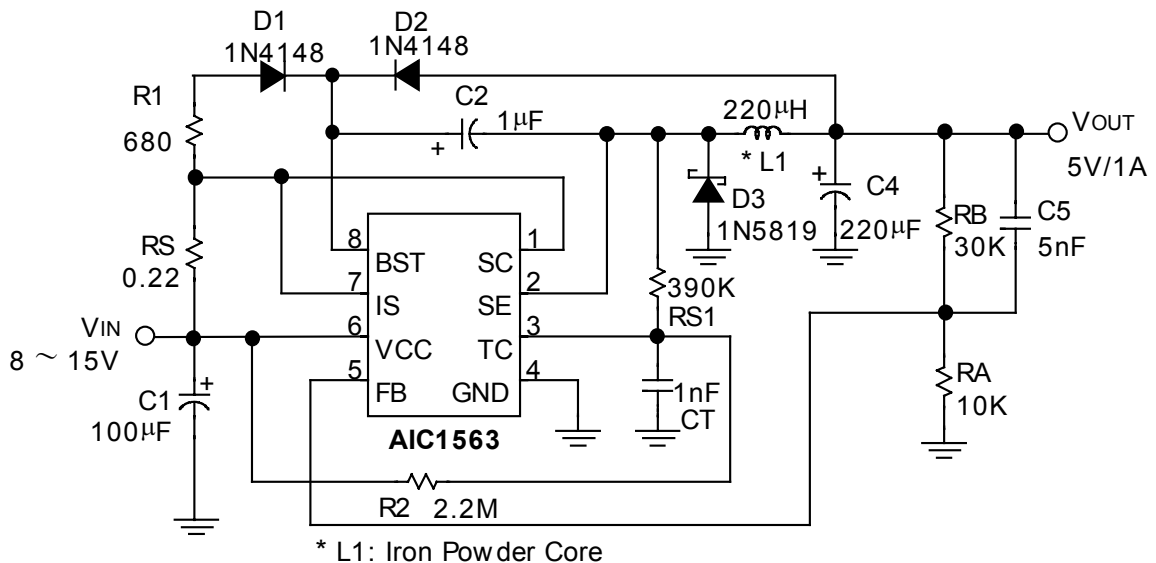

Fig. 6 Application circuit for 5V/1A step-down type constant voltage DC/DC converter

Combining equation (2) and Figure 2 with voltage drops on the switching transistor and free-wheel diode, the voltage difference on the inductor would be (V_{IN}-V_{OUT}-V_{SAT}) if the transistor is switching on, where V_{SAT} is the switching transistor saturation

voltage approximate 0.4 V. The voltage drop on the inductor is (V_{OUT}+V_F) if the transistor is turning off, where V_{SAT} is the forward voltage (0.2 V) of the free-wheel diode. Taking all of these into account, equation (2) can be modified as

$$(V_{IN}-V_{OUT}-V_{SAT}) \times T_{ON}=(V_{OUT}+V_F) \times T_{OFF} \dots\dots(5)$$

and

$$DUTY_{(MAX)}=\frac{T_{ON(MAX)}}{T}$$

$$=\frac{V_{OUT}+V_F}{V_{IN(MIN)}-V_{SAT}+V_F}=66.67\% \dots\dots(6)$$

If we choose the switching frequency as 50 KHz, then the maximum turn-on time of the switching transistor is

$$T_{ON(MAX)}=DUTY_{(MAX)} \times T=66.67\% \times \frac{1}{50K}$$

$$=13.34\mu S \dots\dots(7)$$

For the oscillator in AIC1563, the nominal charging current is 25 μA and its voltage amplitude is 0.6 V. The formula

$$I_{CT}=CT \frac{dV_{CT}}{dt} \dots\dots(8)$$

can be simplified into

$$CT=\frac{I_{CT}}{\Delta V_{CT}} \times T_{ON(MAX)} \dots\dots(9)$$

if the charging current is a DC. It turns out

$$CT=\frac{25 \times 10^{-6} A}{0.6V} \times 13.34\mu S = 556pF \dots\dots(10)$$

Thus, we select CT=470 pF with an operating frequency of 50 KHz.

From the inductor current waveform as shown in Fig. 2, the converter works in a continuous-conduction mode (CCM, the advantage of which is beyond the scope of this note) when the minimum loading current is 100 mA. Then the peak-to-peak current amplitude of the inductor is

$$\Delta IP=2I_{OUT(MIN)}=2 \times 100mA=200mA \dots\dots(11)$$

To maintain the converter in a continuous-conduction mode under a minimum loading current, the minimum inductance can be obtained from Lenz’s law

$$V_L = L \frac{dI}{dt} \dots\dots\dots(12)$$

Based on the inductor voltage waveform in Fig. 3, the minimum inductance is

$$L_{(MIN)} = \frac{\Delta V_L}{\Delta I_P} \times \Delta T$$

$$= \frac{V_{IN} - V_{OUT} - V_{SAT}}{\Delta I_P} \times T_{ON} \dots\dots\dots(13)$$

$$= \frac{(8 - 5 - 0.4)}{200 \times 10^{-3}} \times 13.34 \times 10^{-6} = 173\mu H$$

We select a 220μH inductor for our design. For the consideration of the inductor diameter, a conductor with a cross-sectional area of 1 mm² can take a 3A to 5A current, which depends on the operating temperature. MPP core or inexpensive iron powder core is recommended as the core material of inductor. It is not recommended to use type I inductors because they are only good for low loading current. They can deteriorate the converter efficiency considerably.

The limiting current resistor can be estimated by

$$RS = \frac{0.3V}{I_{LIMIT}} \dots\dots\dots(14)$$

If we set the short circuit protection current to be 1.3 A, then Rs would be 0.25 Ω. The minimum capacitance of the output capacitor is

$$C_{OUT} = \frac{I_{P(MAX)}}{8V_{RIPPLE}F} = \frac{(1 + 0.1)}{8 \times 50 \times 10^{-3} \times 50 \times 10^3} \dots\dots(15)$$

$$= 55\mu F$$

where F is the switching frequency. The output voltage ripple is ΔI_L × ESR , in which

$$ESR = \frac{50 \times 10^{-3}}{200 \times 10^{-3}} = 0.25\Omega \dots\dots\dots(16).$$

In order to reduce the output voltage ripple below to 50 mV, we select a 200 μ F capacitor. If a smaller output voltage ripple is required, a capacitor with a smaller ESR should be considered. Explanation of other circuit elements in Fig. 6 is as follows. C1 is the input filter capacitor. If the changing rate of input voltage is fast, then C1 needs a larger capacitance. C5 is the feedback capacitor, which can increase the dynamic response of converters. RS1 and RS2 are compensation resistors which can stabilize operating frequency to make it work under PWM control method. RS1 provides CT an extra charging path to increase switching frequency. To maintain a switching frequency of 50 KHz, CT is modified to 1nF. R1 and D1 construct a starting circuit to provide AIC 1563 a starting current. Under the normal working condition, the driving current of IC is provided from the output voltage 5 V via the diode D2. Therefore, R1 must limit the voltage between VIN and BST pin to below 5 V.

If the output voltage is 12V, one can modify the circuit elements' values as fore-mentioned.

The experimental results of designing on the relationship between the efficiency and output current and input voltage are plotted in Fig. 7. Other characteristics of the design are listed in table 2.

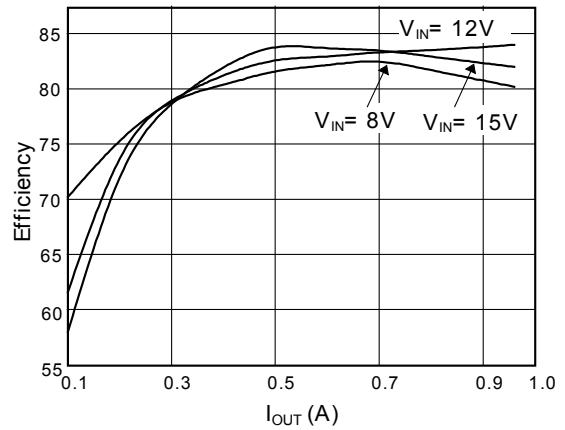

Fig. 7 Efficiency characteristic curves of 5V/1A DC/DC converter

Line Regulator (V _{IN} =8V~15V, I _{OUT} =1A)	50mV
Load Regulation (V _{IN} =12V, I _{OUT} =0.1A~1A)	10mV
Short Circuit Current (V _{IN} =12V)	1.38A

Table 2 Output characteristics of converter

Conclusion

There are many power supplies to provide steady voltage sources for electronic elements in most electronic system products. Only a few electronic systems use dry cell batteries as voltage sources without voltage converter because they consist of a regulator circuit allowing a larger input voltage variation in electronic elements. Based on this, it is important to include a DC/DC voltage converter in an electronic system design. However, most circuit design engineers are unfamiliar with this design technique and often overlook this section of design because it is a small portion of design in electronic system products. In addition to what is described in this application note, it is also critical to consider the layout on a printed circuit board (PCB) when designing a DC/DC voltage converter. Since large current, high voltage and high

frequency signals are used in voltage converter, parasitic inductance and capacitance associated

with PCB layout have an enormous impact on converter characteristics.