



LxF-LP11xx LOW PROFILE OPTICAL TRANSCEIVER

Fast Ethernet Applications

3.3V, 1310nm LED, Multimode, Up to 2.0Km

FEATURES

- Low Profile Design - 0.386 inches max. height
- Surface mount I/O pins for high speed signal integrity
- All metal body, solder or screw mount options
- Industrial Temp Range, Vibration tolerant design
- RX data squelch on Signal Detect deassert
- Individual (separate) +3.3 V power supply per port
- Industry standard duplex multimode LC receptacle
- Full compliance to IEEE 802.3u Fast Ethernet
- EN-60825/ IEC-825 / CDRH Class 1 Compliant
- Optional Parylene C Conformal Coating

APPLICATIONS

The LxF-LP11xx multimode glass optical fiber transceivers provide low profile, cost effective solutions for Fast Ethernet multimode (up to 2.0 Km) optical fiber data links with a duplex LC connector interface.

These transceivers are fully compliant with the IEEE 802.3u Fast Ethernet standard but can be used for any other data communications purpose within their operating parameters.

DESCRIPTION

The LxF-LP11xx fiber optic transceivers consist of transmitter and receiver functions combined in an Low Profile module. The optical transmitter is a high output 1310nm LED. The transmitter input lines are driven with differential LVPECL signals applied to the Transmit (TX+ and TX-) pins. These signals are internally converted to a suitable modulation current by a CMOS integrated circuit.

The optical receivers consist of PIN and Preamplifier assemblies and CMOS limiting post-amplifier integrated circuits. Outputs from the receivers consist of differential LVPECL data signals on the Receive (RX+ and RX-) pins and a single ended LVPECL signal detect function on the Signal Detect (SD) pin. The RX data is squelched (JAM) upon Signal Detect deassert to prevent garbage data output when no optical signal is present.

BLOCK DIAGRAM

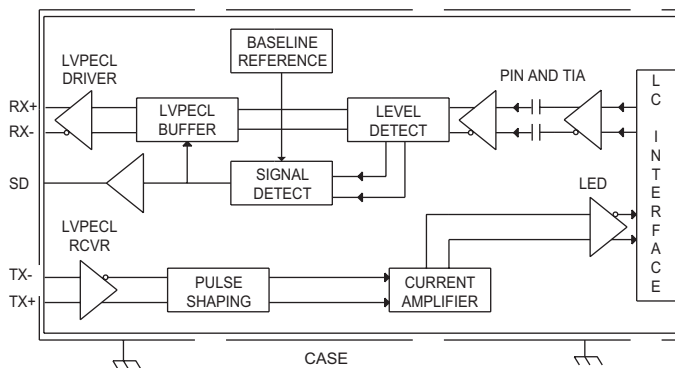

ORDERING INFORMATION

L X F - LP11 X X

Product Family	Shell Options	Application	Optical Wavelength, Signal Detect, Fiber	Temperature and Coating	Mounting
L= Low Profile RJ XCVR	N= No GND Tabs (Flat Shell)	F= Fast Ethernet	LP11= 1310 nm Multimode, LVPECL Signal Detect 3.3VDC Power	H= -40 to 85 C, No Coating	BLANK= Solder Posts (0.125 length)
	T= GND Tabs			M= -40 to 85 C, Conformal Coating	B= Screw Posts (0.050 length)

L _ _ F - LP11 _ _ _

STRATOS

TDS-203F-004
October 5, 2004

Marcel Leukhardt
Sinus-Electronic, Schleifweg 6, 74257 Untereisesheim
Tel.: 07132-9969-14 Fax: 07132-9969-50
@: leukhardt@sinus-electronic.de

LxF-LP11xx LOW PROFILE OPTICAL TRANSCEIVER

Fast Ethernet Applications

3.3V, 1310nm LED, Multimode, Up to 2.0Km

ABSOLUTE MAXIMUM RATINGS

Absolute maximum limits mean that no catastrophic damage will occur if the product is subjected to these ratings for short periods, provided each limiting parameter is in isolation and all other parameters have values within the performance specification. It should not be assumed that limiting values of more than one parameter can be applied to the product at the same time.

Parameter	Symbol	Minimum	Typical	Maximum	Unit
Storage Temperature	T_s	-55		+100	°C
Lead Soldering Temperature	T_{SOLD}			+260	°C
Lead Soldering Time	t_{SOLD}			10	Seconds
Supply Voltage	V_{CC}	-0.5		+4.5	V
Data Input Voltage	V_I	-0.5		V_{CC}	V
Differential Input Voltage (p-p)	V_D			2.0	V
Output Current	I_o			50	mA

RECOMMENDED OPERATING CONDITIONS

Parameter	Symbol	Minimum	Typical	Maximum	Unit
Operating Temperature Limit	T_A	-40		+85	°C
Supply Voltage	V_{CC}	+3.135		+3.465	V
TX Common Mode Voltage	V_{CM}		2.0		V
TX Differential Input Voltage (p-p)	V_D	0.35		1.25	V
RX Data Output Load	R_L		50		Ohms

LxF-LP11xx LOW PROFILE OPTICAL TRANSCEIVER

Fast Ethernet Applications

3.3V, 1310nm LED, Multimode, Up to 2.0Km

TRANSMITTERS

VCCTX = 3.15V to 3.45V, T_A = Operating Temperature Range

Parameter	Symbol	Minimum	Typical	Maximum	Unit
Optical Output Power ¹	P_o	-19.0		-14.0	dBm
Optical Output Center Wavelength	λ_{OUT}	1285	1310	1355	nm
Spectral Width	$\Delta\lambda_{RMS}$ $\Delta\lambda_{FWHM}$			63 175	nm
Extinction Ratio	ER	13			dB
Supply Current	I_{CC}		120	160	mA
Optical Rise / Fall Time	$t_{R,F}$			3.0	ns

1. BER=10⁻¹⁰ @ 125Mbps, PRBS 2⁷-1, NRZ, Compliant with FDDI PMD ISO / IEC 9314-3 and IEEE-802.3u testing with 62.5 MM Fiber.

RECEIVERS

VCCR_X = 3.15V to 3.45V, T_A = Operating Temperature Range

Parameter	Symbol	Minimum	Typical	Maximum	Unit
Optical Sensitivity ¹	P_i	-32.0		-8.0	dBm
Optical Wavelength	λ_{IN}	1260		1380	nm
Supply Current	I_{CC}		70	120	mA
Signal Detect Assert Time	t_{SDAS}		<10	100	μ S
Signal Detect Deassert Time	t_{SDDA}		<10	350	μ S
Signal Detect Threshold ² Decreasing Light	LSTD	-45.0		-32.5	dBm
Increasing Light	LSTI	-45.0		-32.0	dBm
Signal Detect Hysteresis	HYS	0.5	2.25	3.5	dB
RX Data Output - Low	$V_{OL} - V_{CC}$	-1.810		-1.475	V
RX Data Output - High	$V_{OH} - V_{CC}$	-1.165		-0.880	V

1. BER=10⁻¹⁰ @ 125Mbps, PRBS 2⁷-1, NRZ, Compliant with FDDI PMD ISO / IEC 9314-3 and IEEE-802.3u testing with 62.5 MM Fiber

2. RX Data outputs are squelched when Signal Detect is deasserted to prevent garbage data output when no optical signal is present. .

LxF-LP11xx LOW PROFILE OPTICAL TRANSCEIVER

Fast Ethernet Applications

3.3V, 1310nm LED, Multimode, Up to 2.0Km

CONFORMAL COATING OPTION

Parameter	Value
Specification	MIL-I-46058C, Type XY
Coating:	Parylene type C
Deposition:	Vacuum deposited
Film Thickness:	1 MIL +/- 0.0002

LINK DISTANCES

Application	Fiber Specification	Distance
Fast Ethernet - IEEE 802.3u	62.5/125 - 500MHz*Km	2.0Km
FDDI PMD ISO / IEC 9314-3	50/125 - 500MHz*Km	2.0Km

REGULATORY COMPLIANCE

Requirement	Feature	Condition	Notes
MIL-STD-883-3015.7	ESD	Class II	2200V
IEC-801-2	ESD	Human Body Model	25KV
IEC-801-3	EMI	Immunity	10V/M
FCC	EMI	Class B	>20dB
EN 55022 (CISPR 22A)	EMI	Class B	10V/M
IEC-825 Issue 1993-11	Eye Safety	Class 1	TUV Certificate Number One File
FDA CDRH 21-CFR 1040	Eye Safety	Class 1	CDRH Accession Number On File

LxF-LP11xx LOW PROFILE OPTICAL TRANSCEIVER

Fast Ethernet Applications

3.3V, 1310nm LED, Multimode, Up to 2.0Km

Low Profile Optical Transceiver
Top View Shown

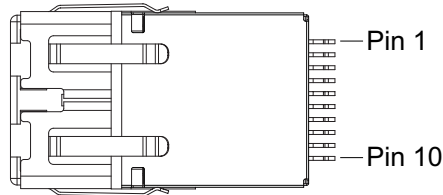

PIN FUNCTIONS

Pin Number	Symbol	Description	Logic Family
GP	GP	Grounding Posts Connect to chassis ground	N/A
1	TD+	Transmitter DATA In	LVPECL
2	VEETX	Transmitter Signal Ground	N/A
3	TD-	Transmitter DATA In	LVPECL
4	VCCTX	Transmitter Power Supply	N/A
5	SD	Signal Detect Satisfactory Optical Input: Logic "1" Output Fault Condition: Logic "0" Output External 150 Ohm pull-down recommended	LVPECL
6	N/C	No Connect - leave open	N/A
7	RD+	Receiver DATA Out	LVPECL
8	VCCR _X	Receiver Power Supply	N/A
9	RD-	Receiver DATA Out	LVPECL
10	VEER _X	Receiver Signal Ground	N/A

LxF-LP11xx LOW PROFILE OPTICAL TRANSCEIVER

Fast Ethernet Applications

3.3V, 1310nm LED, Multimode, Up to 2.0Km

Parallel Termination (Thevenin Equivalent) for DC Coupled LVPECL PHY devices

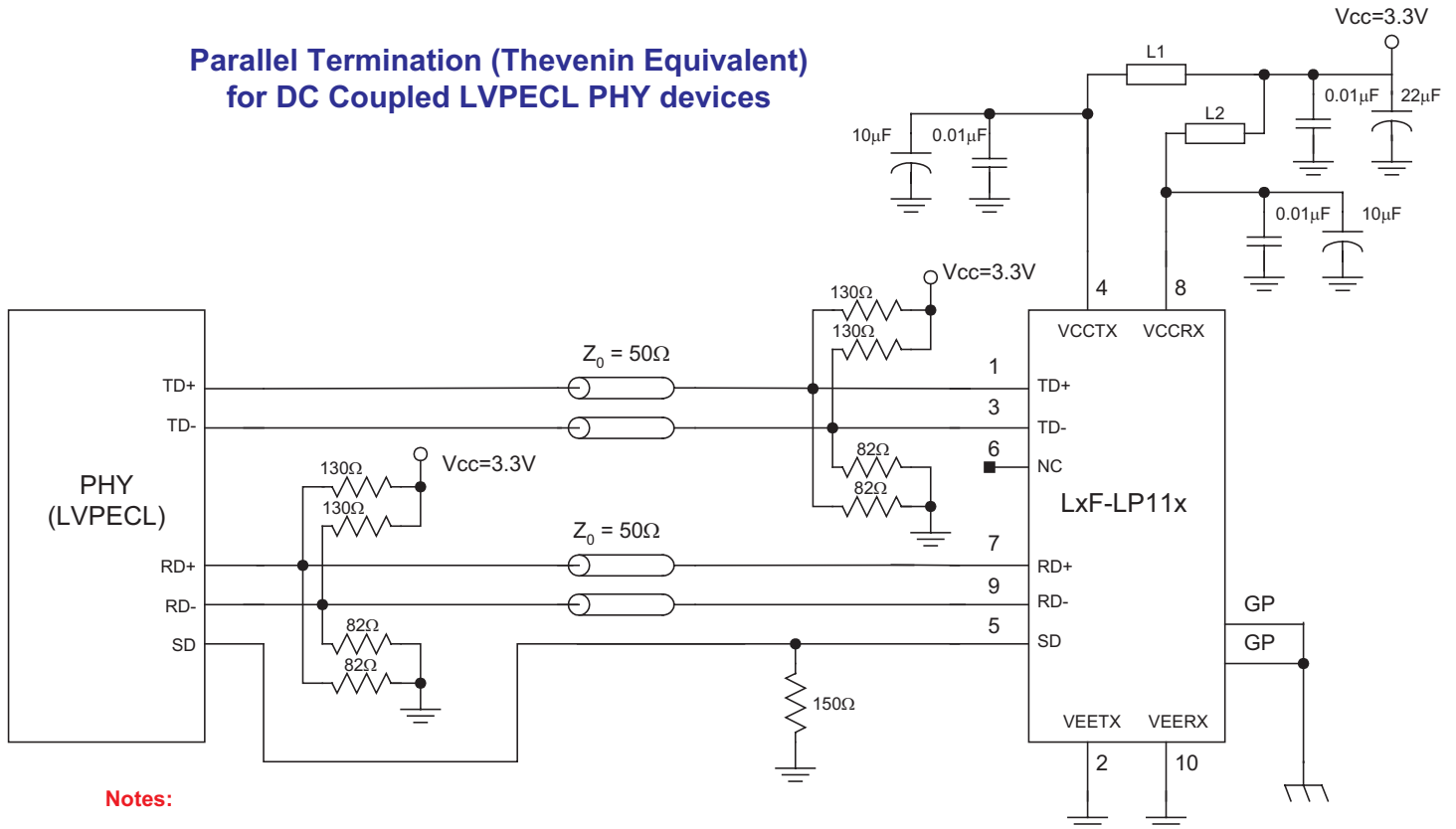

Notes:

- 1) L1 and L2 = MuRata BLM21A601S or equivalent (600Ω at 100MHz or better).
- 2) Place LVPECL termination resistors (130 / 82 ohms) as close as possible to termination points.
- 3) Route the differential pairs (TD +/- and RD +/-) together using 50 ohm impedance matched traces.
- 4) Other DC coupled LVPECL termination techniques are also valid.
- 5) Use separate power supply filtering for VCCTX and VCCR X, as shown.
- 6) Ground Posts (GP) are isolated from Signal Ground (Vee), and may be connected to Chassis Ground (as shown) or to Signal Ground if a Chassis Ground is not available.

LxF-LP11xx LOW PROFILE OPTICAL TRANSCEIVER

Fast Ethernet Applications

3.3V, 1310nm LED, Multimode, Up to 2.0Km

Parallel Termination (Thevenin Equivalent) for AC Coupled LVPECL PHY devices

Similar to DC-coupled, except addition of emitter follower pull-down resistors (180 ohms), different V_t operating point (2.0V versus 1.1V), and addition of series RF capacitors.

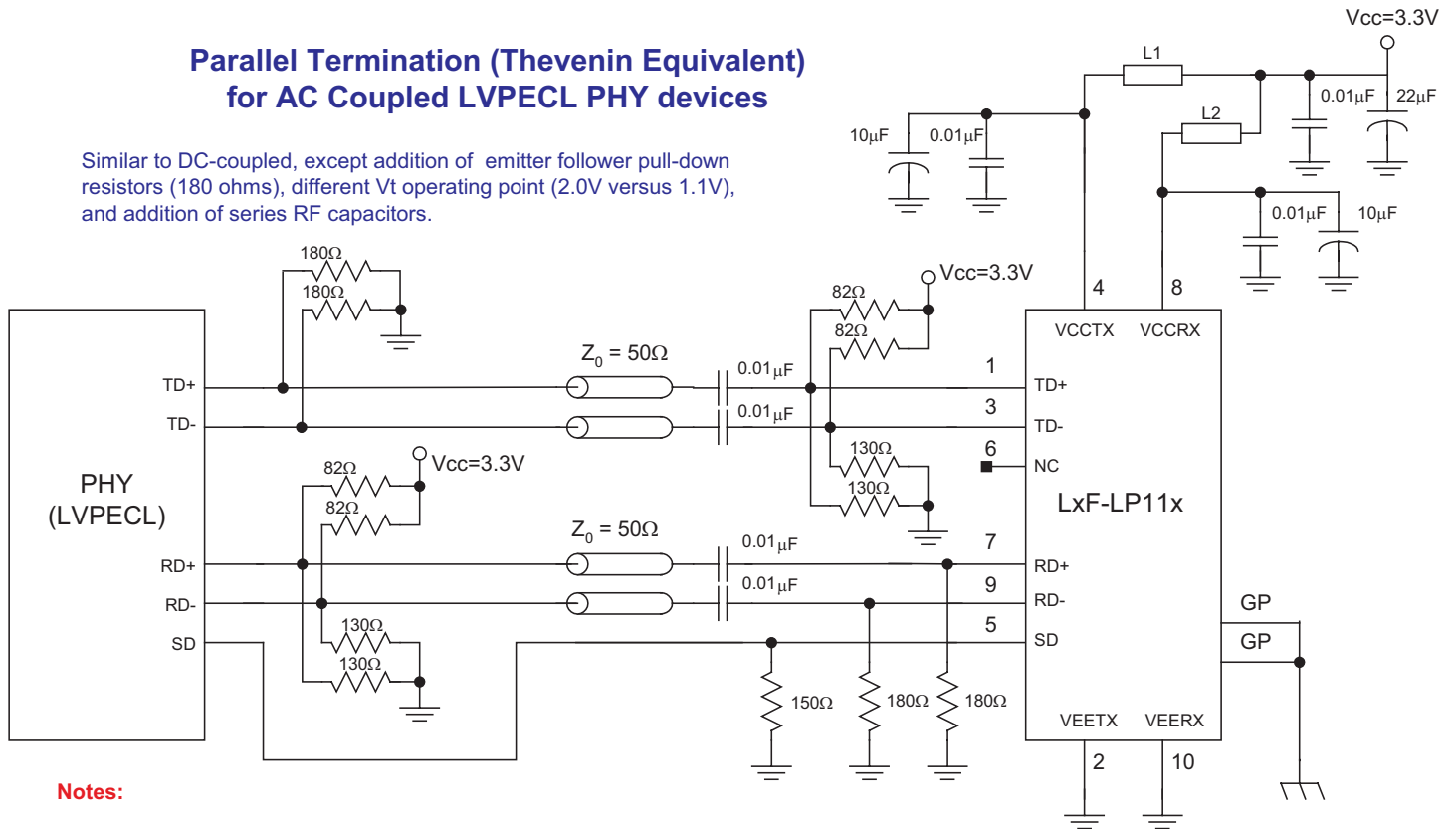

Notes:

- 1) L1 and L2 = MuRata BLM21A601S or equivalent (600 Ω at 100MHz or better).
- 2) Place LVPECL termination resistors (82 / 130 ohms) as close as possible to termination points. Place LVPECL emitter follower pull-down (180 ohms) as close as possible to source points.
- 3) Route the differential pairs (TD +/- and RD +/-) together using 50 ohm impedance matched traces.
- 4) Other AC coupled LVPECL termination techniques are also valid.
- 5) Use separate power supply filtering for VCCTX and VCCR, as shown.
- 6) Ground Posts (GP) are isolated from Signal Ground (Vee), and may be connected to Chassis Ground (as shown) or to Signal Ground if a Chassis Ground is not available.
- 7) Use low ESR capacitors, such as NPO or COG, for AC coupling of TD +/- and RD +/- signals.

LxF-LP11xx LOW PROFILE OPTICAL TRANSCEIVER

Fast Ethernet Applications

3.3V, 1310nm LED, Multimode, Up to 2.0Km

LOW PROFILE OPTICAL TRANSCEIVER PCB FOOTPRINT

Dimensions Are Shown As: $\frac{\text{mm}}{\text{(inches)}}$

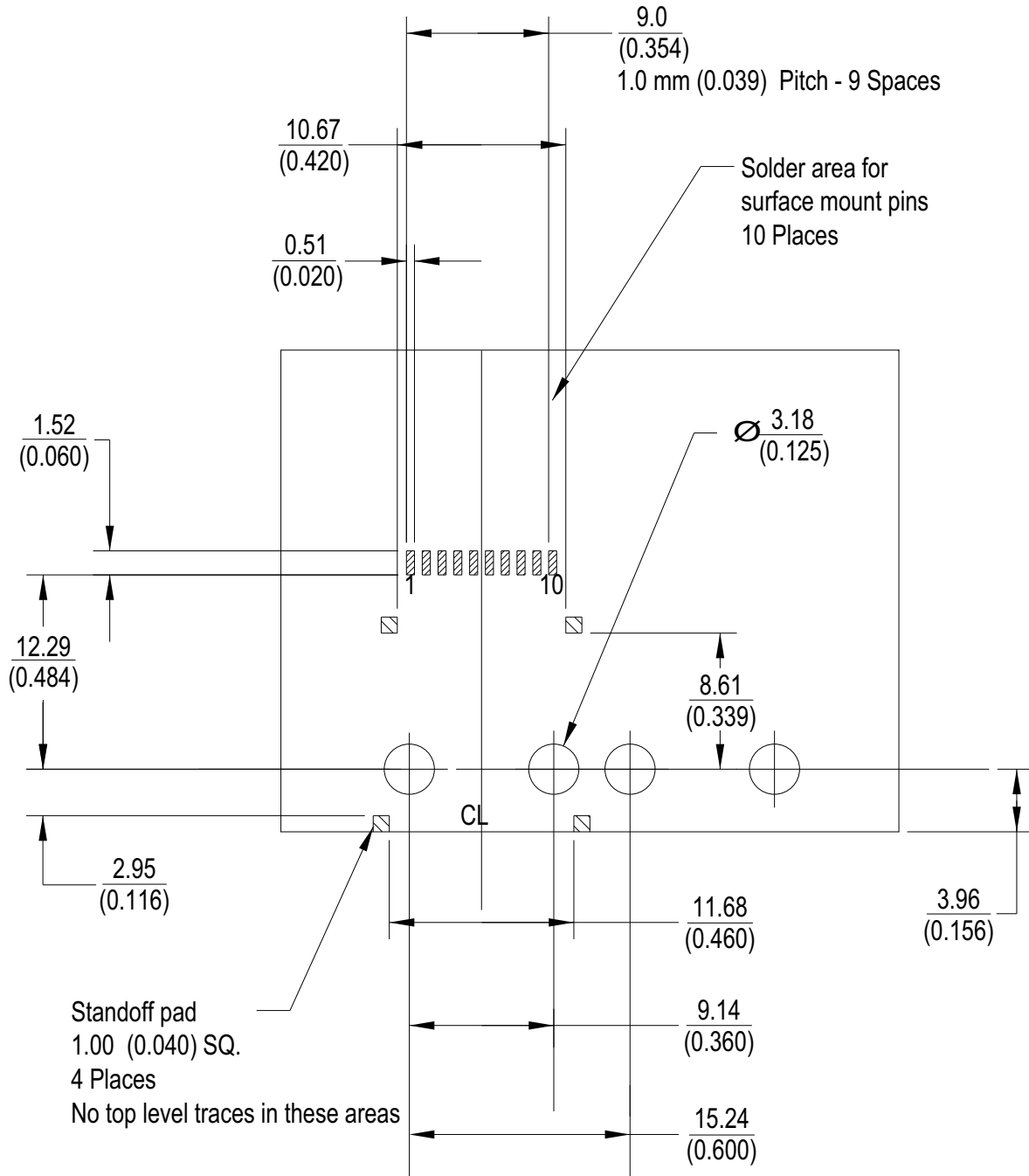

Top View Shown

STRATOS

TDS-203F-004
October 5, 2004

Marcel Leukhardt
Sinus-Electronic, Schleifweg 6, 74257 Untereisesheim
Tel.: 07132-9969-14 Fax: 07132-9969-50
@: leukhardt@sinus-electronic.de

LxF-LP11xx LOW PROFILE OPTICAL TRANSCEIVER

Fast Ethernet Applications

3.3V, 1310nm LED, Multimode, Up to 2.0Km

MECHANICAL DETAIL (SOLDER POST VERSION)

GROUND CLIP SHELL

FLAT SHELL

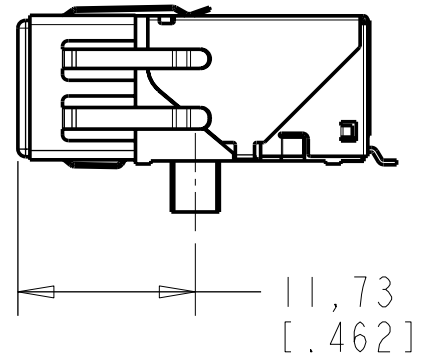
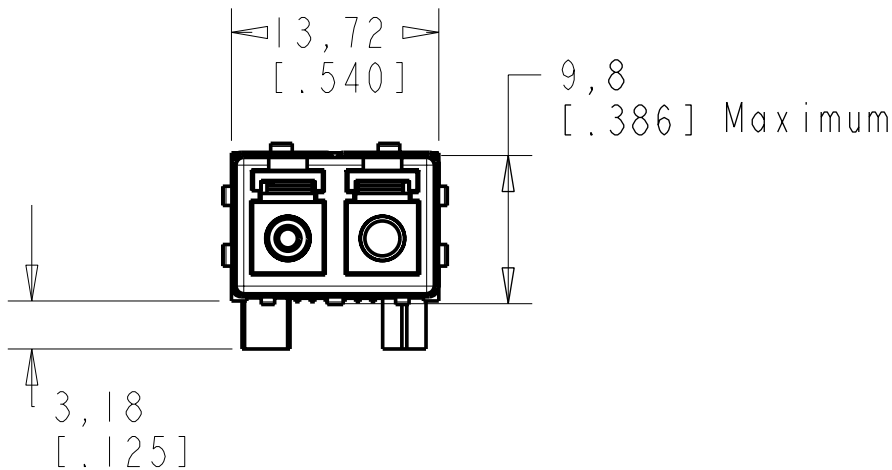
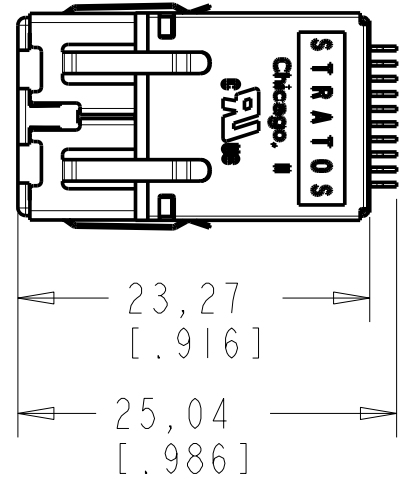
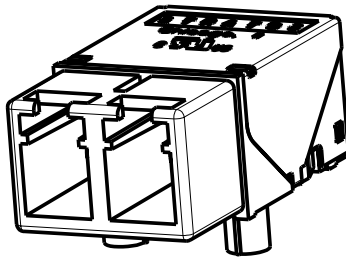
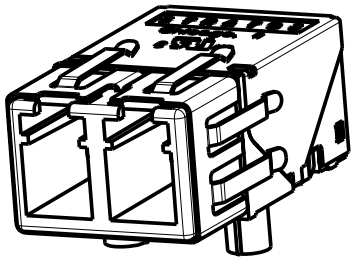

RECOMMENDED PANEL CUT-OUT
for PROPER GROUND CLIP CONTACT
is 0.400 X 0.560 INCHES.

STRATOS

TDS-203F-004
October 5, 2004

Marcel Leukhardt
Sinus-Electronic, Schleifweg 6, 74257 Untereisesheim
Tel.: 07132-9969-14 Fax: 07132-9969-50
@: leukhardt@sinus-electronic.de

LxF-LP11xx LOW PROFILE OPTICAL TRANSCEIVER

Fast Ethernet Applications

3.3V, 1310nm LED, Multimode, Up to 2.0Km

MECHANICAL DETAIL (SCREW POST VERSION)

GROUND CLIP SHELL

FLAT SHELL

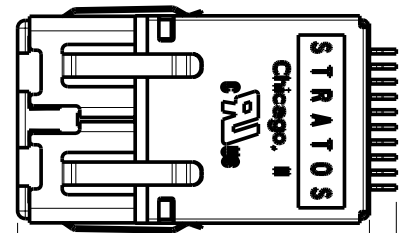
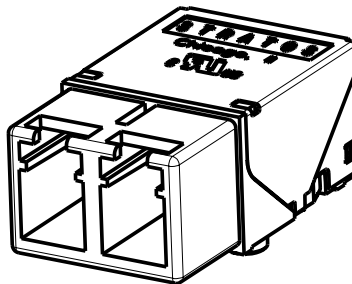
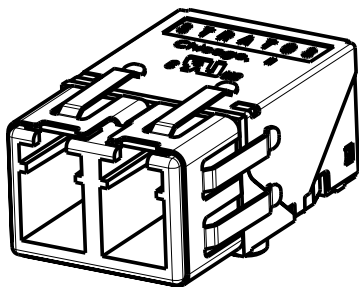

23,27
[.916]

25,04
[.986]

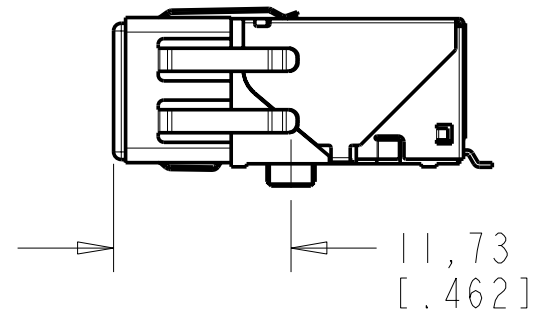
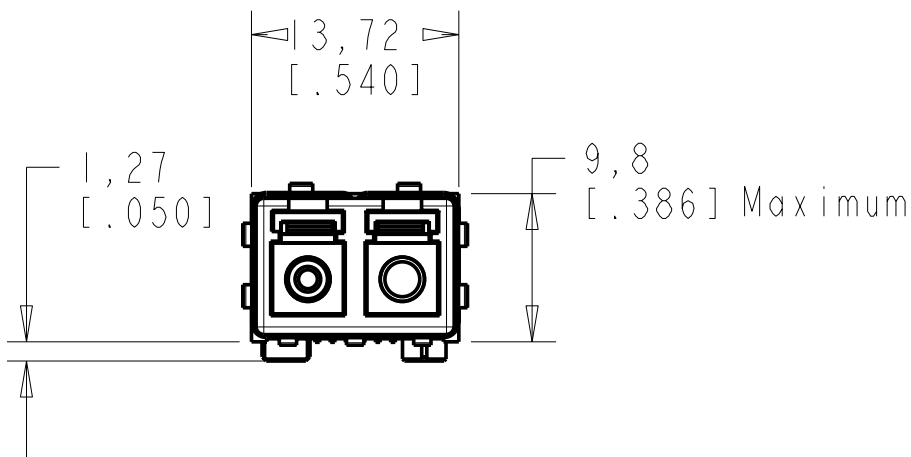

RECOMMENDED PANEL CUT-OUT
for PROPER GROUND CLIP CONTACT
is 0.400 X 0.560 INCHES.

STRATOS

TDS-203F-004
October 5, 2004

Marcel Leukhardt
Sinus-Electronic, Schleifweg 6, 74257 Untereisesheim
Tel.: 07132-9969-14 Fax: 07132-9969-50
@: leukhardt@sinus-electronic.de

LxF-LP11xx LOW PROFILE OPTICAL TRANSCEIVER

Fast Ethernet Applications

3.3V, 1310nm LED, Multimode, Up to 2.0Km

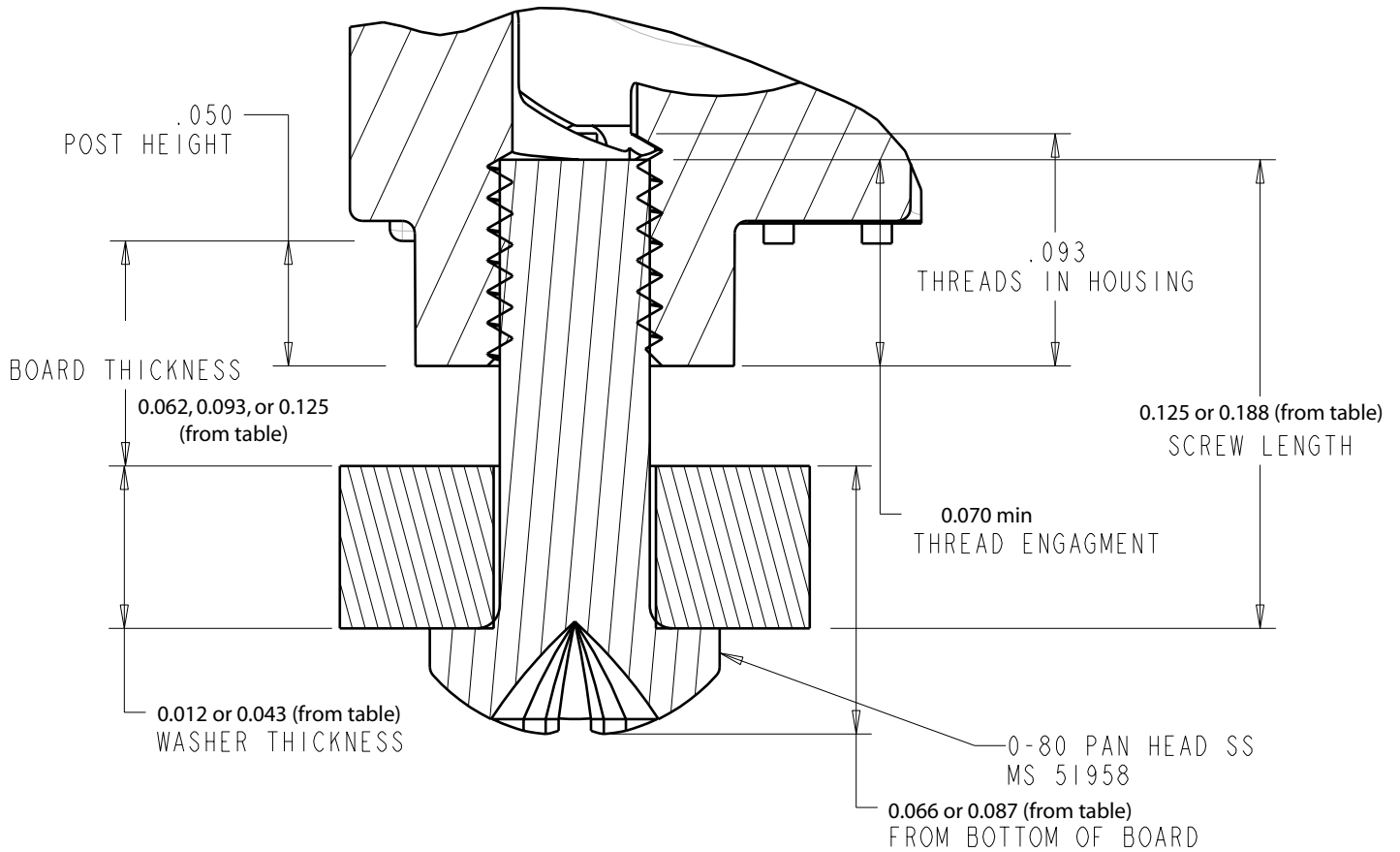

PCB Nominal Thickness	Screw Length	Washer Thickness	Screw/Washer Height	Order Stratos Washer	Order Stratos Screw
0.062 in +/- 0.005	0.125 in	0.043 in	0.087 in	751-00002	618-00001
0.093 in +/- 0.005	0.125 in	0.012 in	0.066 in	751-00001	618-00001
0.125 in +/- 0.005	0.188 in	0.043 in	0.087 in	751-00002	618-00002

Notes:

1) Customer may choose to any type 0-80 Stainless Steel (SS) screw configuration (pan head, flat head, hex head, etc) as long as the thread engagement is less than 0.93 inches max into the Low Rider housing.

2) Customer can order 0-80 SS pan head screws and washers from Stratos for standard sized PCB thicknesses as identified in the table. The Stratos part number is identified for the screw/washer combination for each of three standard sized PCB thicknesses. Be sure to order 2 washers and 2 screws per Low Rider device.

3) Torque screws to 7 to 9 in-oz for a clamping force of 36 to 47 lbs per screw. Do not exceed 16 in-oz torque per screw.



LxF-LP11xx LOW PROFILE OPTICAL TRANSCEIVER

Fast Ethernet Applications

3.3V, 1310nm LED, Multimode, Up to 2.0Km

PART NUMBER SUMMARY AND OPTIONS

Part Number	Flat Shell	Clip Shell	Conf Coat	Solder Posts	Screw Posts
LNF-LP11H	X			X	
LNF-LP11M	X		X	X	
LNF-LP11HB	X				X
LNF-LP11MB	X		X		X
LTF-LP11H		X		X	
LTF-LP11M		X	X	X	
LTF-LP11HB		X			X
LTF-LP11MB		X	X		X

IMPORTANT NOTICE

Stratos Lightwave, Inc. reserves the right to make changes to or discontinue any optical link product or service identified in this publication, without notice. Stratos Lightwave recommends that its customers obtain the latest version of the publications to verify, before placing orders, that the information being relied on is current. Stratos Lightwave warrants performance of its optical link products to current specifications in accordance with the Stratos Lightwave standard warranty. Testing and other quality control techniques are utilized to the extent that Stratos Lightwave has determined it to be necessary to support this warranty. Specific testing of all parameters of each optical link product is not necessarily performed on all optical link products. Stratos Lightwave products are not designed for use in life support appliances, devices, or systems where malfunction of a Stratos Lightwave product can reasonably be expected to result in a personal injury. Stratos Lightwave customers using or selling optical link products for use in such applications do so at their own risk and agree to fully indemnify Stratos Lightwave for any damages resulting from such improper use or sale. Stratos Lightwave assumes no liability for Stratos Lightwave applications assistance, customer product design, software performance, or infringement of patents or services described herein. Nor does Stratos Lightwave warrant or represent that a license, either expressed or implied is granted under any patent right, copyright, or intellectual property right, and makes no representations or warranties that these products are free from patent, copyright, or intellectual property rights. Applications that are described herein for any of the optical link products are for illustrative purposes only. Stratos Lightwave makes no representation or warranty that such applications will be suitable for the specified use without further testing or modification.

