

MDB-9-6-1-V 1x Fibre Channel -- 1.0625GBaud 850nm Media Interface Adpater (MIA)



ORDERING INFORMATION

MDB - 9 - 6 - 1 - V

V = Extended Voltage Range

WAVELENGTH

1 = 850 nm (multimode)

PROTOCOL

6 = 1x Fibre Channel; 1.0625GBaud



Optoelectronic Products

7444 West Wilson Avenue • Chicago, IL 60656
708/867-9600 • 800/323-6858 • Fax: 708/867-0996
email:optoinfo@stratoslightwave.com
http://www.stratoslightwave.com

Features

- 1.0625 Gbps Fibre Channel compliant
- SC Duplex Optical Interface
- DB-9 Electrical Interface
- 150Ω differential PECL level Inputs/Outputs
- Die Cast Metal Housing
- Class 1 Laser Safety Compliant
- UL 1950 Approved

PRODUCT OVERVIEW

The MDB-9-6-1-V Extender module is a high performance integrated duplex data link for bi-directional communication over multimode optical fiber in Fibre Channel applications. It is compliant with the Media Interface Adapter (MIA) specification. The MDB-9-6-1-V Fiber Optic Extender is specifically designed to connect to electrical high speed data communications links that require extended distance performance. The previous limit of 25m in copper connections can easily be extended to 550m with 50µm multimode fiber at data rate of 1.0625GBaud.

This optoelectronic transceiver module is a class 1 laser product compliant with FDA Radiation Performance Standards, 21 CFR Subchapter J. This component is also a class 1 laser compliant according to the International Safety Standard IEC-825-1.

SHORT WAVELENGTH LASER

The use of short wavelength Vertical Cavity Surface Emitting Lasers (VCSELs) and high volume production processes has resulted in a low cost, high performance product which communicates reliably at distances of 550m over 50µm and 300m over 62.5µm multimode optical fiber with data rate of 1.0625 GBaud.

MODULE SPECIFICATIONS - ABSOLUTE MAXIMUM RATINGS

PARAMETER	SYMBOL	MIN	MAX	UNITS	NOTES
Storage Temperature	Tstg	-40	+85	°C	
Supply Voltage	Vcc		6.25	V	Vcc - ground
Data AC Voltage	Tx+, Tx-		2.6	Vpp	Differential
Data DC Voltage	Tx+, Tx-	-10	10	Vpk	V (Tx+ or Tx-) - ground

MODULE SPECIFICATION - RECOMMENDED OPERATING CONDITIONS

PARAMETER	SYMBOL	MIN	TYP	MAX	UNITS	NOTES
Operating Case Temperature	Tc	0		+70	°C	
Supply Voltage	Vcc	+3.15	+5.0	+5.5	VDC	
Baud Rate	BRate		1.0625		GBaud	±100ppm

MDB-9-6-1-V 1x Fibre Channel -- 1.0625GBaud 850nm Media Interface Adapter (MIA)



PERFORMANCE SPECIFICATIONS - ELECTRICAL

0°C<Tc<+70°C; +3.15V<Vcc<+5.5V

PARAMETER	SYMBOL	MIN	TYP	MAX	UNITS	NOTES
Supply Current	Icc		180	200	mA	Tc = 25°C, Vcc = +5.0 V
				250	mA	0°C<Tc<+70°C, +3.15 V< Vcc <+5.5V
In-Rush Current	I _{surge}			4	A	50µs duration -- maximum
TRANSMITTER						
PECL Inputs (Differential)		400		1600	mVpp	AC coupled inputs
Input Impedance (Differential)	Z _{in}	135	150	165	ohms	R _{in} > 100Kohms @ DC
ODIS Input Voltage (High)	V _{iH}	2		V _{cc}	V	
ODIS Input Voltage (Low)	V _{iL}	0		0.8	V	
RECEIVER						
PECL Outputs (Differential)		600	1200	1860	mVpp	AC Coupled Outputs
Output Impedance (Differential)	Z _{out}	135	150	165	ohms	
FAULT- Output Voltage (High)	V _{oH}	2.4	3.0	V _{cc}	V	I _o = 400µA
FAULT- Output Voltage (Low)	V _{oL}	0	0.25	0.6	V	I _o = -4.0mA
Total Jitter [Pk - Pk]	TJ			75	ps	Measured with 2 ⁷ - 1 PRBS @ 2.125GBaud
				130		Measured with 2 ⁷ - 1 PRBS @ 1.0625GBaud

MDB-9-6-1-V OPTICAL SPECIFICATIONS --- 850 nm Laser Multimode

0°C<Tc<+70°C; +3.15V<Vcc<+5.5V

PARAMETER	SYMBOL	MIN	TYP	MAX	UNITS	NOTES
50µm Core Diameter MMF		550	1000		m	BER<1.0E-12 @ 1.0625GBaud
62.5µm Core Diameter MMF		300	500		m	BER<1.0E-12 @ 1.0625GBaud
TRANSMITTER						
Optical Center Wavelength	λ	830	850	860	nm	
Spectral Width	Δλ			1.0	nm	RMS
Optical Transmit Power	P _{opt}	-10		-2 ¹	dBm	Average @ 850nm
Optical Modulation Amplitude	OMA	160			µW	pk-pk
Relative Intensity Noise	RIN			-117	dB/Hz	
Total Jitter [Pk - Pk]				170	ps	Measured with 2 ⁷ - 1 PRBS
Output Rise/Fall Time				320	ps	20%-80%; Measured unfiltered
RECEIVER						
Optical Input Wavelength	λ	770		860	nm	
Optical Input Power		-17		0		BER<1.0E-12 @ 1.0625GBaud
Optical Modulation Amplitude		31				pk-pk
Optical Return Loss	ORL	12			dB	
Link Fault- --- Asserted				-17		Measured on transition -- High to Low
Link Fault- --- Deasserted	P _d	-29			dBm	Measured on transition -- Low to High
Link Fault- --- Hysteresis	P _a - P _d		1.5	5	dB	

Note¹ - Lessor of Class 1 Laser Safety Limits (CDRH and EN 60825) or receiver power, max.

MDB-9-6-1-V 1x Fibre Channel -- 1.0625GBaud 850nm Media Interface Adapter (MIA)



ELECTRICAL INTERFACE - PIN DESCRIPTIONS

PIN 1	TX+	Non-inverted data into the MIA transmit input. The input is internally AC coupled and terminated with a 75 ohm resistor to AC ground.
PIN 2	Vcc	Regulated power supply provided by the host. The host will fuse this power output.
PIN 3	FAULT -	Active low signal. Fault - is the logical NOR that a module fault or link fault condition has been detected. A module fault is defined as the failure of the optical output of the MIA and is internally latched. A link fault is defined as the loss of signal at the receiver. Zero on this pin indicates a optical fault or the absence of optical input signal. On the rising edge of ODIS, the latched optical fault will be cleared and FAULT- will remain deasserted while ODIS is asserted. The host shall provide a 4.7K to 10K ohm pull up resistor to Vcc.
PIN 4	KEY	There is no connection. This pin is removed.
PIN 5	RX+	Non-inverted output data from the MIA. The output is internally AC Coupled PECL level and is expected to drive into a 75ohm load.
PIN 6	TX-	Inverted data into the MIA transmit input. The input is internally AC coupled and terminated with a 75 ohm resistor to AC ground.
PIN 7	ODIS	Active high optical output disable signal. This signal is driven by the host. While asserted, the MIA module disables all laser light output. This pin is internally pulled up to Vcc through 10 Kohm resistor. ODIS must be pulled low or connected to circuit ground by the host to enable the MIA output.
PIN 8	GND	This is the circuit ground connection for the module and is not connected to the chassis ground via the MDB-9 case.
PIN 9	RX-	Inverted output data from the MIA. The output is internally AC Coupled PECL level and is expected to drive into a 75ohm load.
	SHIELD	D-sub metal shell connected to module case.. This is typically connected to chassis ground via the host connector shell.

INTERFACE TIMING VALUES

Description	Symbol	Min	Typ	Max	Units
Minimum ODIS assertion time to clear a module fault condition	Tpw_fault_reset	100			nsec
Delay from laser over power fault detect to FAULT- assertion	Tpd_modfault_on			1	msec
Laser on time from deassertion of ODIS	Tpd_ON			2	msec
Laser off time from assertion of ODIS	Tpd_OFF			2	msec
Delay from deassertion of Loss of Light condition to deassertion of FAULT-	Tpd_LOL_OFF			2	msec
Delay from assertion of Loss of Light condition to assertion of FAULT-	Tpd_LOL_ON			2	msec
Delay from assertion of ODIS to clear FAULT-	Tpd-FAULT-_reset			1	µsec

MDB-9-6-1-V 1x Fibre Channel -- 1.0625GBaud 850nm Media Interface Adapter (MIA)



TYPICAL INTERFACE OPERATION FOR MODULE FAULT CONDITION

Figure 2: Illustrates typical interface operation for the event of a module fault condition.

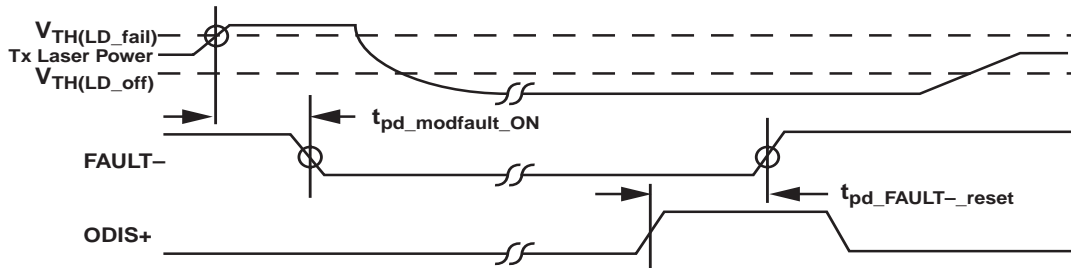

Figure 2: Module Fault Interface Example

TYPICAL INTERFACE OPERATION FOR LINK FAULT CONDITION

Figure 3: Illustrates interface operation for a typical link fault condition

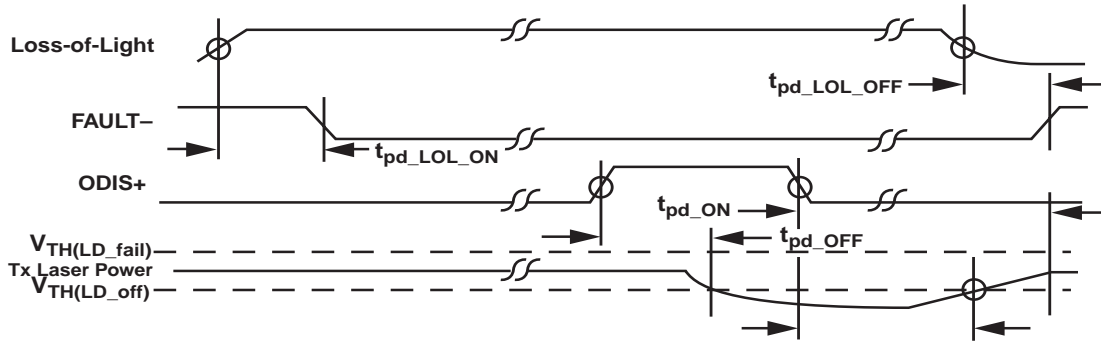

Figure 3: Typical Interface Operation for Link FAULT- Event

TYPICAL INTERFACE OPERATION - COMBINED MODULE AND LINK FAULT

Figure 4: Illustrates the operational scenario for the event of a combined module and link fault

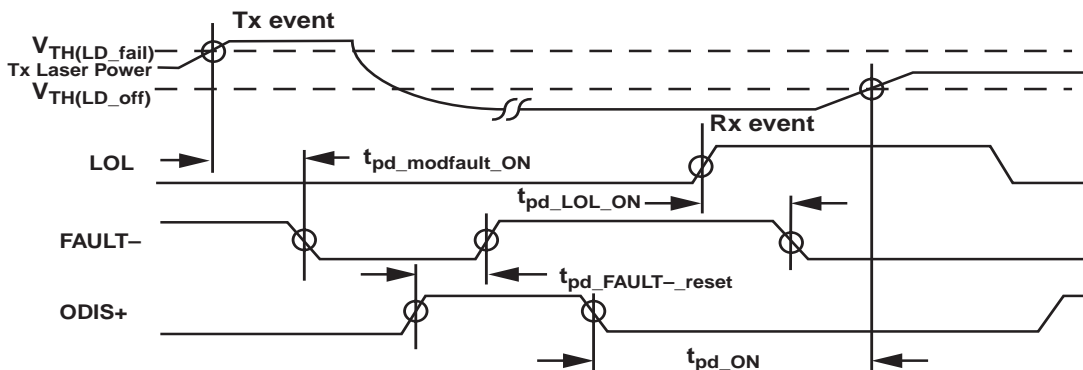
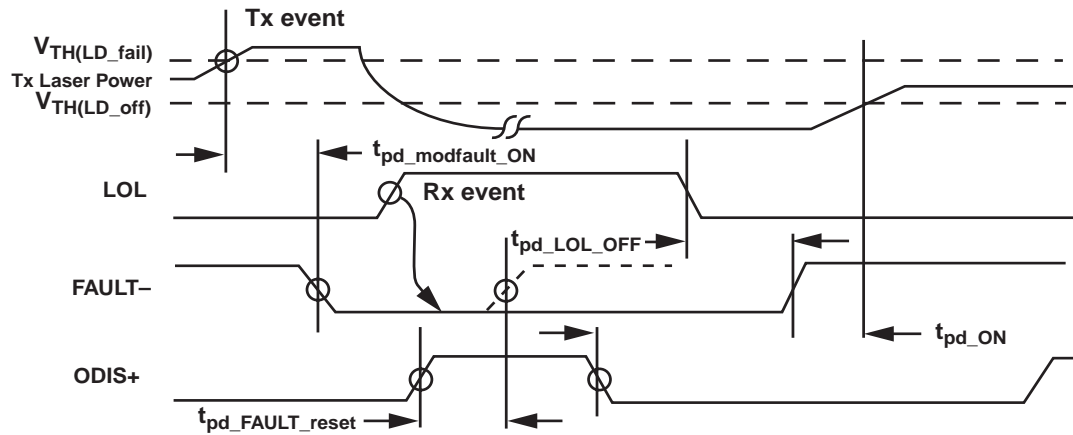

Figure 4: Typical operation – Combined module and link fault event



TYPICAL INTERFACE OPERATION FOR MODULE FAULT CONDITION



note: the assertion of ODIS clears only the module fault condition. FAULT - will remain asserted until the LOL condition is cleared

Figure 5: Typical operation - Pre-existing module fault followed by link fault (LOL) condition

TYPICAL INTERFACE OPERATION – POWER ON EVENT

Figure 5 Illustrates typical interface operation during power on and hot plugging events

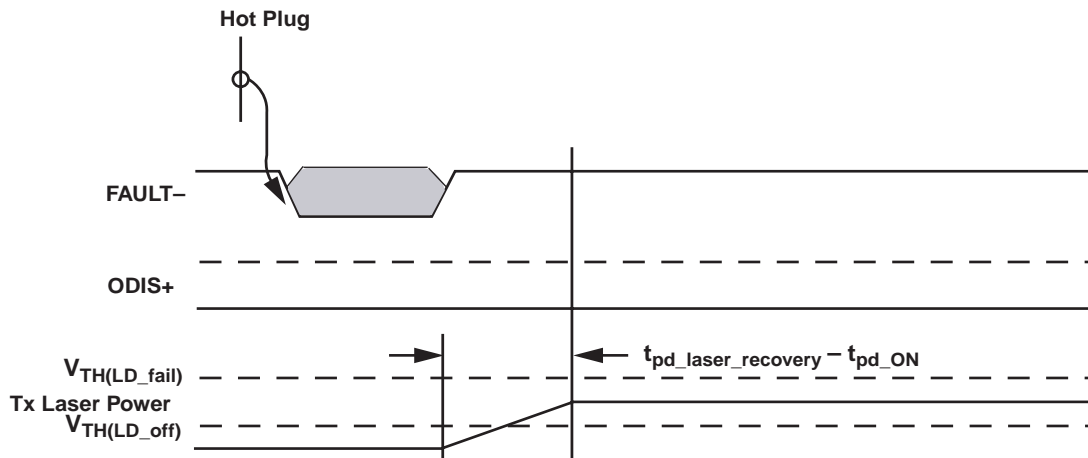

Figure 6: Power on and Hot Plug Operation

MDB-9-6-1-V 1x Fibre Channel -- 1.0625GBaud 850nm Media Interface Adpater (MIA)



TERMINATION CIRCUITS

Inputs to the transmitter section of the MDB-9-6-1-V are AC coupled with an internal termination of 75 ohms to AC ground (See TRANSMIT Termination). Any variation in the impedance of the module can be attributed to parasitic contributions of the module pins or interface connector. The inputs require a transmitter signal with at least a 400mVp-p signal swing (differential). Outputs from the receiver section of the module are AC coupled CML level and are expected to drive into a 75 ohm load (See RECEIVE Termination).

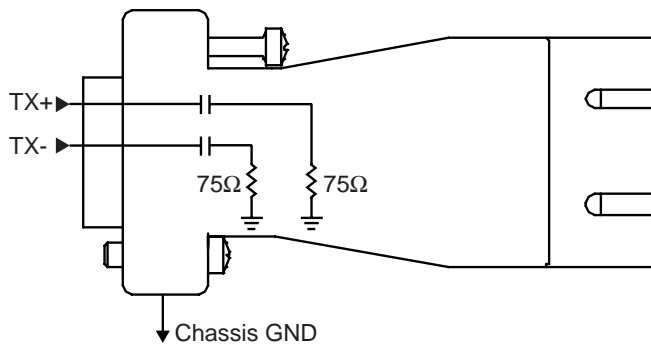

Figure 1. TRANSMIT Termination

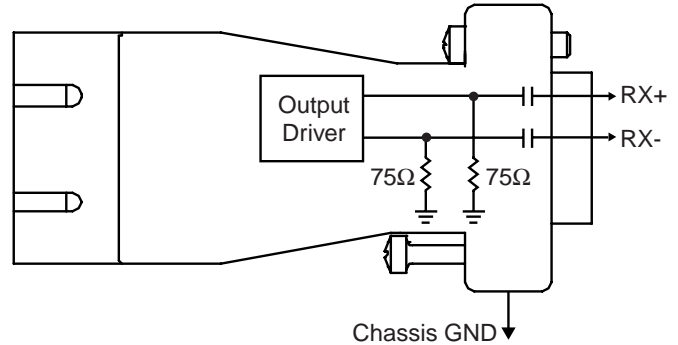

Figure 2. RECEIVE Termination

A suggested termination for the FAULT- pin is shown in Figure 3. Zero on this pin (Active Low) indicates the absence of the optical input signal or a laser fault. The host shall provide a pull-up resistor to Vcc of 4.7 to 10 K ohms.

POWER COUPLING

A suggested circuit for external power supply filtering is given in Figure 4. Bypass capacitors should be placed as close to the DB-9 connector as possible. The host shall provide a fused power link to the MIA. The fuse shall be capable of handling a 4 amp inrush current for 50 microseconds.

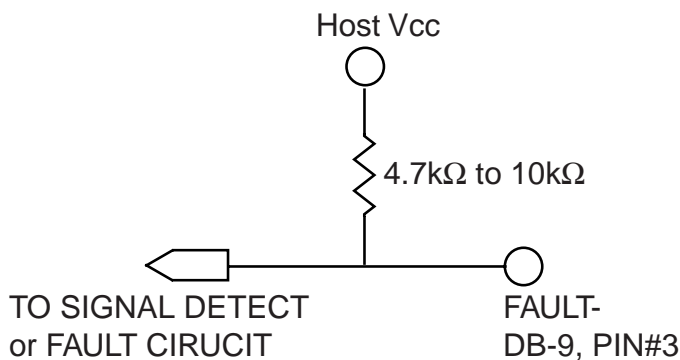

Figure 3. Host Card "FAULT-" Termination

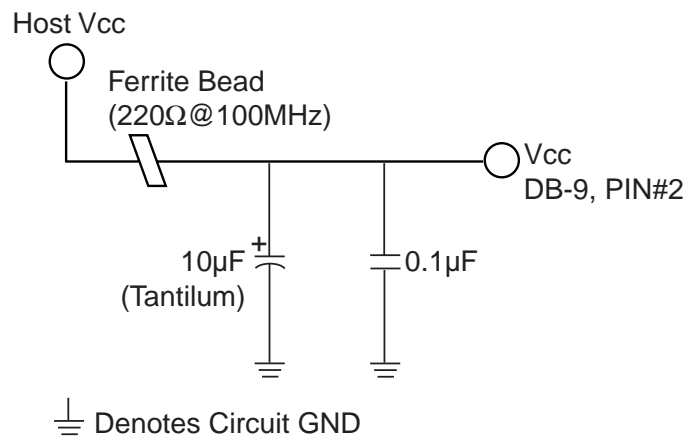
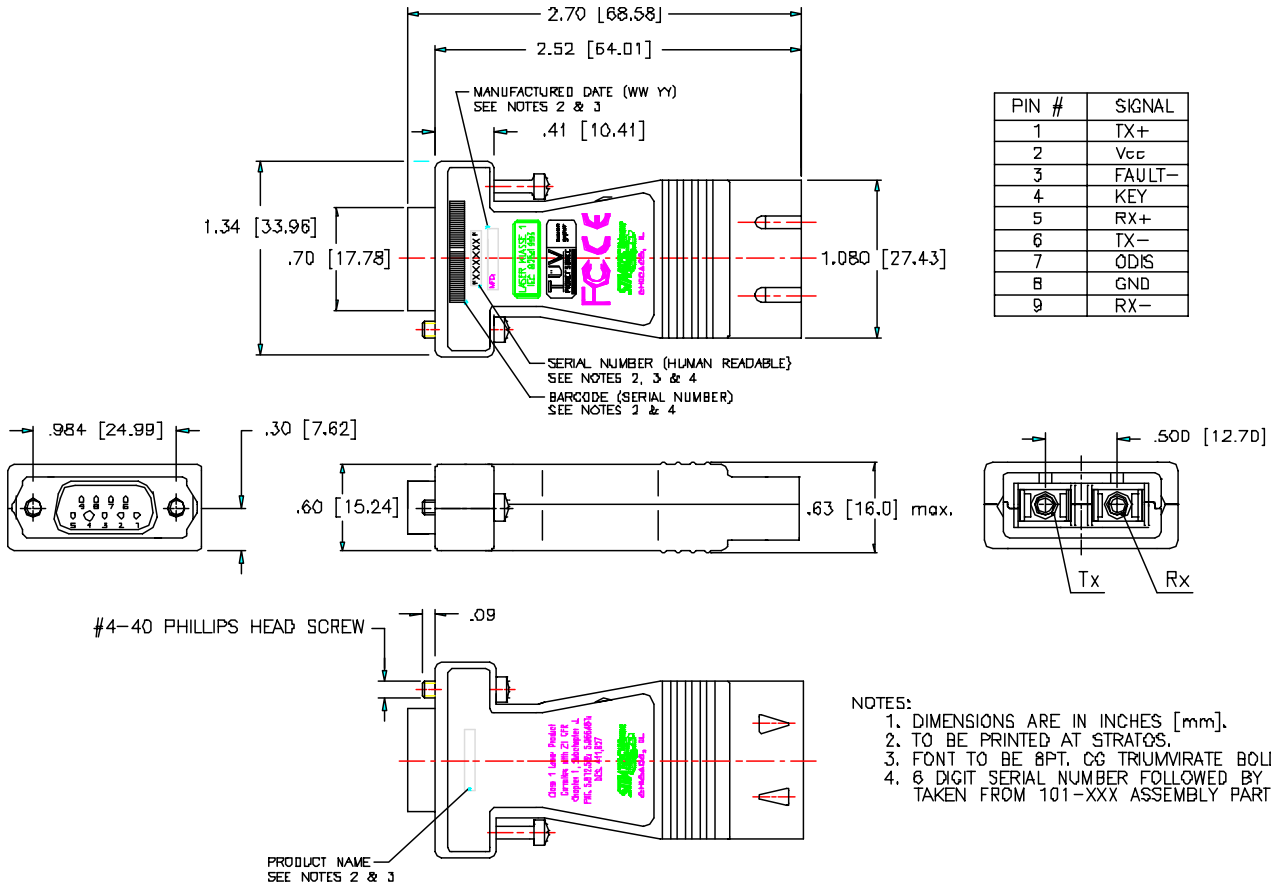

Figure 4. Suggested Power Coupling

MDB-9-6-1-V 1x Fibre Channel -- 1.0625GBaud 850nm Media Interface Adapter (MIA)



MECHANICAL DIMENSIONS



Optoelectronic Products

7444 West Wilson Avenue • Chicago, IL 60656
 708/867-9600 • 800/323-6858 • Fax: 708/867-0996
 email: optoinfo@stratoslightwave.com
 http://www.stratoslightwave.com

MDB-9-6-1-V 1x Fibre Channel -- 1.0625GBaud 850nm Media Interface Adapter (MIA)



REGULATORY COMPLIANCE

The Stratos Lightwave optoelectronic extender module offers a metalized case which is connected to chassis ground when installed on the host device. The mounting screws must be securely attached to assure minimal radiated emissions from the MDB-9-6-1-V module.

The following advisory is required by FCC regulation:

Tested to comply with FCC standards FOR HOME OR OFFICE USE

Important Information to the user:

This equipment has been tested and found to comply with the limits for a Class B digital device pursuant to Part 15 of the FCC Rules. These limits are designed to provide reasonable protection against harmful interference in a residential installation. This equipment generates, uses and can radiate radio frequency energy and if not installed and used in accordance with the instructions, may cause harmful interference to radio communications. However there is no guarantee that interference will not occur in a particular installation. If this equipment does cause harmful interference to radio or television reception, which can be determined by turning the equipment off and on, the user is encouraged to try to correct the interference by one or more of the following measures.

- Reorient or relocate the receiving antenna.
- Increase the separation between the equipment and the receiver.
- Connect the equipment into an outlet on a circuit different from that to which the receiver is connected.
- Consult the dealer or an experienced radio/TV technician for help.

By law, changes or modifications not expressly approved by Stratos Lightwave could void the user's authority to operate the MDB-9-6-1 Fibre Channel Media Interface Adapter.

LASER SAFETY REGULATORY COMPLIANCE

This optoelectronic transceiver module is a Class 1 Laser product complying with FDA Radiation Performance Standards, 21 CFR, Chapter 1, Subchapter J. This component is also Class 1 Laser compliant according to International Standard IEC825-1.

Operating this module outside of specifications or altering the module from the manufacturer's original design may result in hazardous radiation exposure and may be considered new manufacturing of a laser product by government regulations. Persons performing such an act are required by law to re-certify and re-identify this product.

Optoelectronic Products

7444 West Wilson Avenue • Chicago, IL 60656
(708) 867-9600 • (800) 323-6858 • Fax: (708) 867-0996
email:optoinfo@stratoslightwave.com
<http://www.stratoslightwave.com>

IMPORTANT NOTICE

Stratos Lightwave reserves the right to make changes to or discontinue any optical link product or service identified in this publication, without notice, in order to improve design and/or performance. Stratos Lightwave advises its customers to obtain the latest version of the publications to verify, before placing orders, that the information being relied on is current.

Stratos Lightwave warrants performance of its optical link products to current specifications in accordance with Stratos Lightwave standard warranty. Testing and other quality control techniques are utilized to the extent that Stratos Lightwave has determined it to be necessary to support this warranty. Specific testing of all parameters of each optical link product is not necessarily performed on all optical link products.

Stratos Lightwave products are not designed for use in life support appliances, submarines, military, flight hardware, devices, or systems where malfunction of a Stratos Lightwave product can reasonably be expected to result in a personal injury. Stratos Lightwave customers using or selling optical link products for use in such applications do so at their own risk and agree to fully indemnify Stratos Lightwave for any damages resulting from such improper use or sale.

Stratos Lightwave assumes no liability for Stratos Lightwave applications assistance, customer product design, software performance, or infringement of patents or services described herein. Nor does Stratos Lightwave warrant or represent that a license, either expressed or implied is granted under any patent right, copyright, or intellectual property right, and makes no representations or warranties that these products are free from patent, copyright, or intellectual property rights.

Applications that are described herein for any of the optical link products are for illustrative purposes only. Stratos Lightwave makes no representation or warranty that such applications will be suitable for the specified use without further testing or modification.