



The Stratos 950 Series harsh environment connectors are designed for deployment in the toughest applications where high performance and total reliability are critical. The 950 Series is based on the familiar MIL C 38999 product series, benefiting from Stratos expanded beam technology, with a long and proven industry track record. The precision optical alignment system creates immunity from water, mud, dust, oil and other contaminants which normally ingress the optical path and rapidly deteriorate performance in a field environment.

Ideally suited for retro fit and system upgrades from electrical to optical transition. The 950 Series, is the favoured military solution, with its quick mate bayonet coupling it is widely used within many internal communications systems guaranteeing durability and stability.

The 950 Series delivers a proven pedigree and world beating capability.

Features:

- MIL C 38999 shell size 14
- Advanced expanded beam technology
- 2 or 4 Multimode Fibre channels
- Bayonet style coupling

Benefits:

- Compliments existing infrastructures
- Rapid interconnection
- 90° Plugs and user orientated backshells
- Easy clean

Applications:

- Military tactical communications
- Petrochemical
- Aerospace
- Broadcast

Materials:

- Shell and dust cap - Aluminium
- Plating material - Cadmium olive drab



Performance:	
Optical Loss	50/125 @ 850/1300nm 1.5 dB typ
Operating temperature	-40 to +70°C
Storage temperature	-55 to +85°C
Vibration Sinusoidal	57-500Hz, 0.75 amplitude @ 10g acceleration
Free fall resistance	500 falls onto concrete from 1.2M height
Bump resistance	4000 bumps @ 40g acceleration
Tensile Strength	Tensile of 1500N, cable dependent
Cable Variations	Compatible with tactical cable: ≤8mm outer diameter Other cable sizes available on request

All tests compliant to BS EN 186000-1 specifications

Technical Drawings

All dimensions are in mm

950 Series Straight Plug

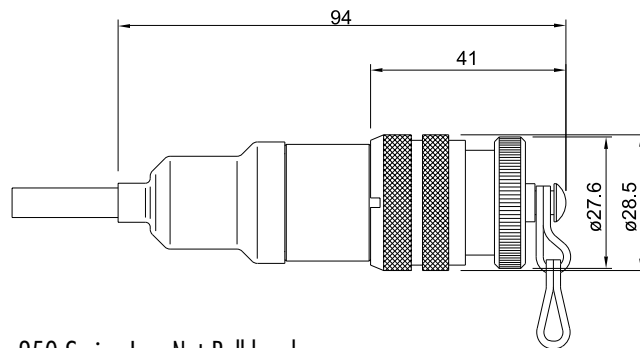

950 Series Right Angled Plug

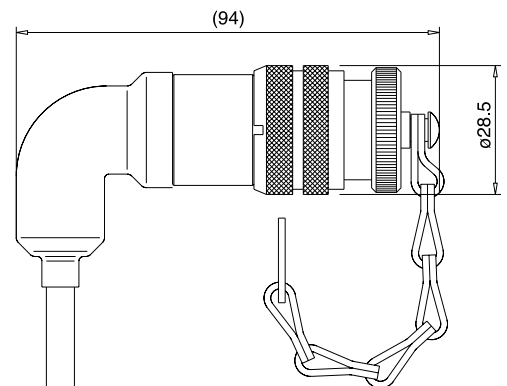

950 Series Jam Nut Bulkhead

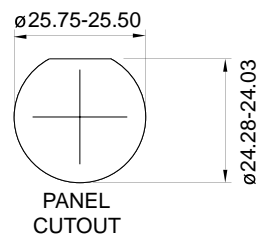
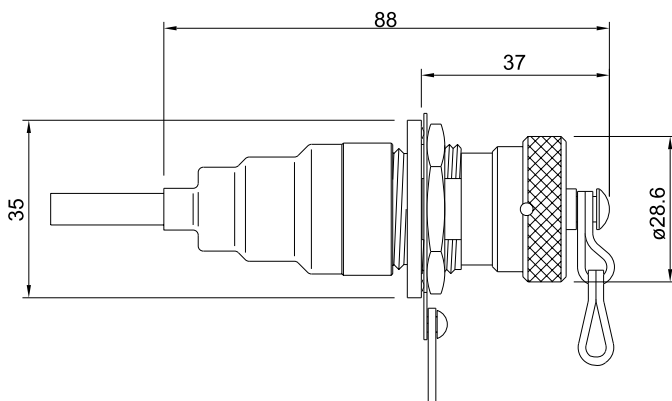

Planforms

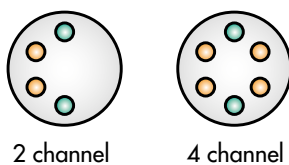

2 channel

4 channel



Hollands Road Industrial Estate, Haverhill,
Suffolk CB9 8PR England
Tel +44(0)1440 706441 Fax +44(0)1440 762044

Protective caps are included with assemblies unless otherwise stated
Termination and repair kits are available

Stratos Ltd. is registered to BS EN ISO9001

Whilst due care has been taken to ensure the contents of this data sheet are accurate, Stratos Lightwave™ cannot accept liability for any errors or omissions that may occur. We reserve the right to alter specifications of products without prior notice.

Sofortkontakt unter:
Herr Michael Vollmann
+49 7132 9969-15
E-Mail: vollmann@sinus-electronic.de

